

GRUNFARS

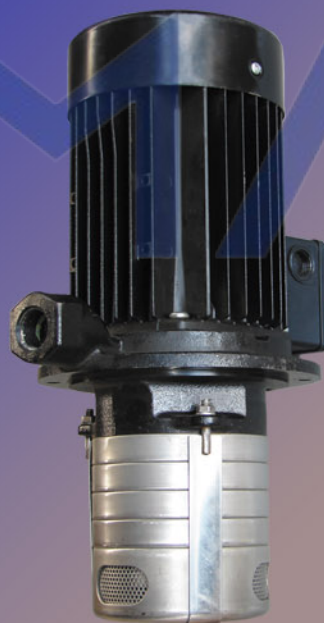

Family



GRUNFARS



Family

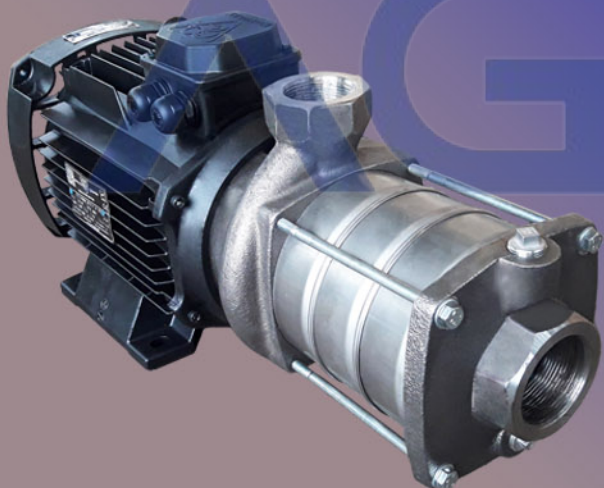



GRUNFARS

GRUNFARS

GRUNFARS

CR4

CR4

CR4

Mid East

GRUNFARS



Pumps

CRI PUMPS

Special FOR portable RO dialydid



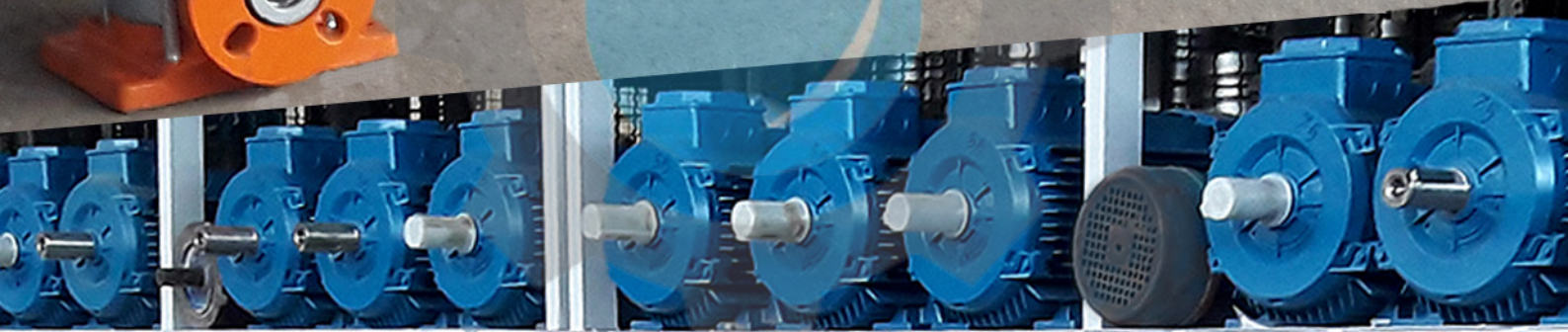

Mid East

GRUNFARS



Pumps

**Fire & Explosion Proof
CRI Pumps**





GRUNFARS

CR16

AEB-D.K

Midd, East

GRUNFARS

Pumps

CR1 & CRI1 SERIES



CR1/CRN1

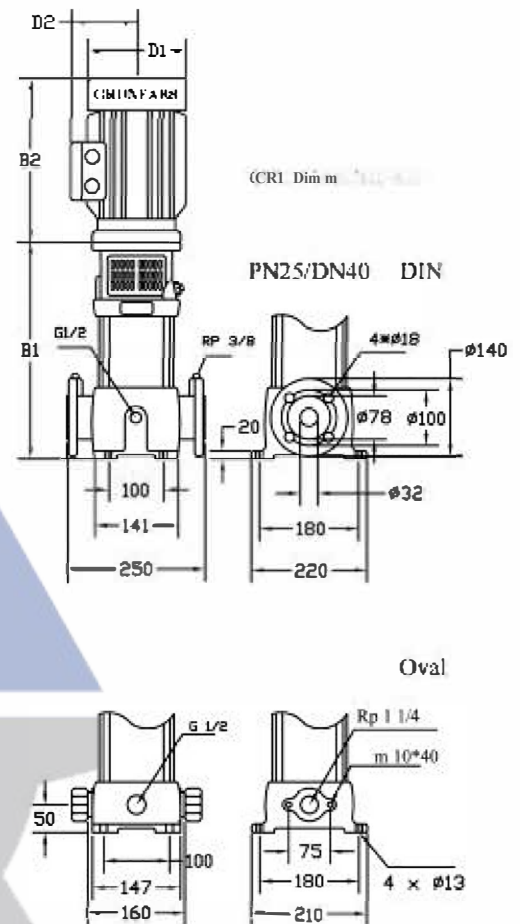
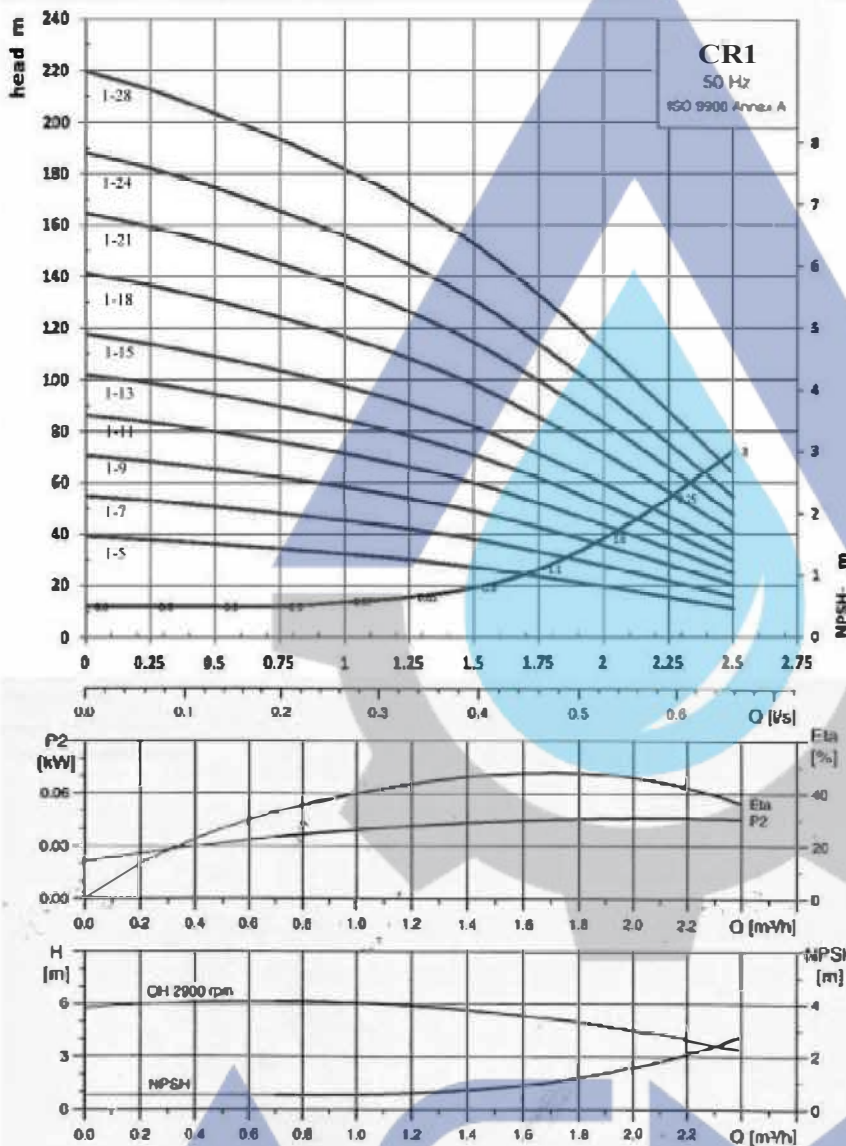

Dimensions and weights

pump type	DIMENSIONS [mm]							Net Weight [kg]	
	* B1	B2	** B1+B2	* B1	** B1+B2	D1	D2	*	**
CR1-5	275	190	465	300	490	140	110	20	25
CR1-7	315	230	545	340	570	140	110	25	30
CR1-9	350	230	580	375	605	140	110	30	35
CR1-11	385	230	615	410	640	140	110	30	35
CR1-13	440	280	720	465	745	180	110	30	35
CR1-15	475	280	755	500	780	180	110	30	35
CR1-18	511	280	835	555	835	180	110	50	50
CR1-21	655	280	905	625	905	180	110	55	55
CR1-24	709	335	960	679	905	180	110	60	60
CR1-28	781	335	1040	705	1040	180	110	60	60

* CR1 With Oval flanges

** CR1 With DIN flanges

Pipework connection

■ DIN 2566 with threaded socket

□ DIN/2634/2635 with socket for welding

* Oval flange base for pump models CR15 TO CR1-28

** DIN flange base for pump models CR15 TO CR1-28



Materials CR1/CRN1

POS. NO.	Description	Materials	DIN W.-NO	AISI / ASTM
1	Pump head	Cast iron GG20	0.6020	ASTM 25B
* 2	Cupling guard	stainless steel	1.4301	AISI 304
3	shaft	stainless steel	1.4401 1.4057	AISI 316 AISI 431
* 4	impeller	stainless steel	1.4301	AISI 304
* 5	intermediate chamber	stainless steel	1.4301	AISI 304
* 6	Outer sleeve	stainless steel	1.4301	AISI 304
	Stay bolts	stainless steel or steel 50	1.4057 1.0531	AISI 431
* 7	Base	Cast iron GG20	0.6020	ASTM 25B
8	Neck ring	Teflon		
9	shaft seal	Tungesten carbide Silicon carbide		
	Rubber parts in pump	EPDM or FPM (viton)		

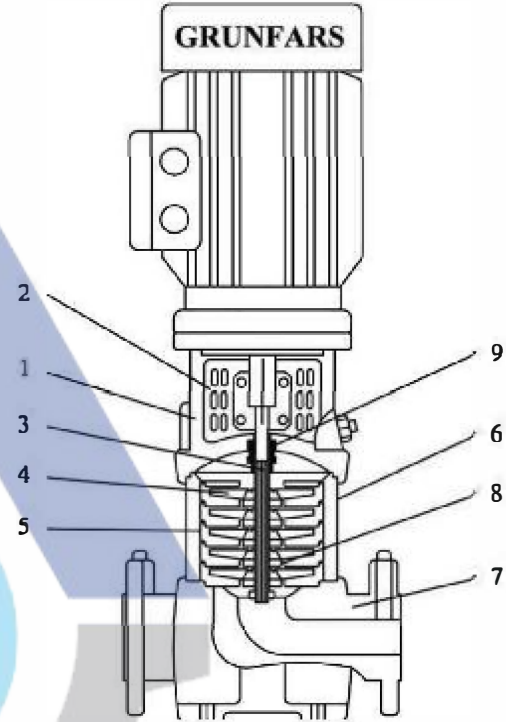

Material for Position No. Marked * in CRN Type is -
Stainless Steel (1.4401 AISI 316)

Electrical Data

pump type	Motor		Full load current I _{1/1} [A]	Power Factor Cosφ 1/1	Motor Efficiency η [%]	$\frac{I_{start}}{I_{1/1}}$
	[KW]	[hp]				
CR1-5	0.37	0.5	0.96	0.84-0.76	77.5-77.5	4.8-5.2
CR1-7	0.37	0.5	0.96	0.84-0.76	77.5-77.5	4.8-5.2
CR1-9	0.55	0.75	1.44	0.84-0.76	79.0-79.0	4.8-5.2
CR1-11	0.55	0.75	1.44	0.84-0.76	79.0-79.0	4.8-5.2
CR1-13	0.75	1.0	1.86	0.86-0.78	80.0-80.0	5.0-5.5
CR1-15	0.75	1.0	1.86	0.86-0.78	80.0-80.0	5.0-5.5
CR1-18	1.5	2.0	3.40	0.85-0.79	82.0-82.0	6.3-6.9
CR1-21	1.5	2.0	3.40	0.85-0.79	82.0-82.0	6.3-6.9
CR1-24	2.2	3.0	4.75	0.87-0.82	84.0-84.0	7.0-7.6
CR1-28	2.2	3.0	4.75	0.87-0.82	84.0-84.0	7.0-7.6

Midd, East

GRUNFARS

Pumps

CR2 & CRI2 SERIES



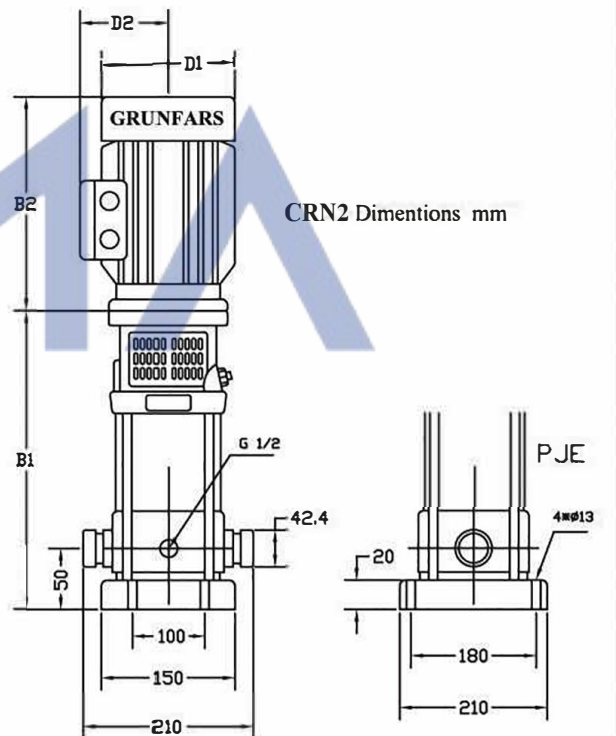
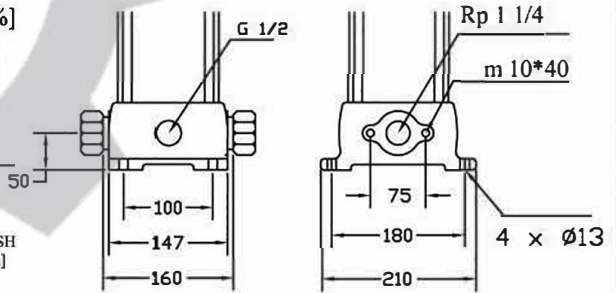
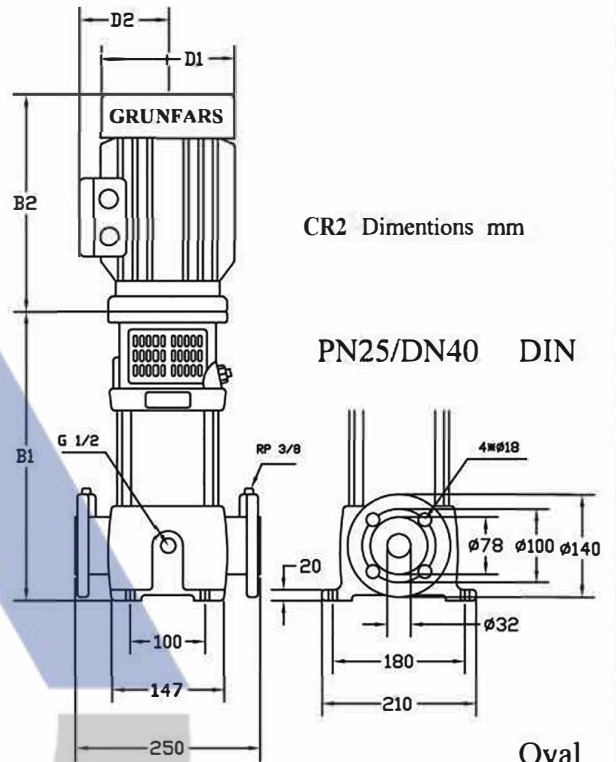
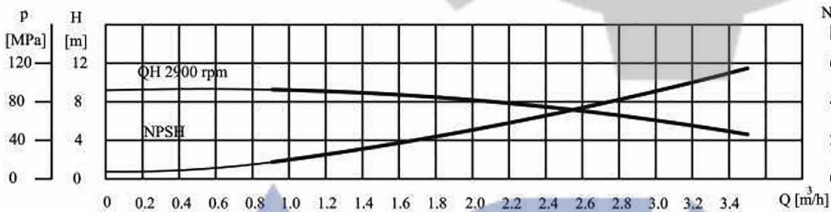
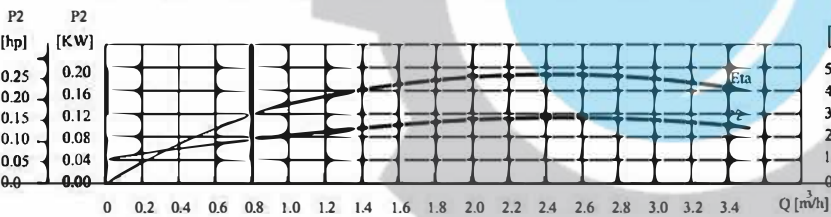
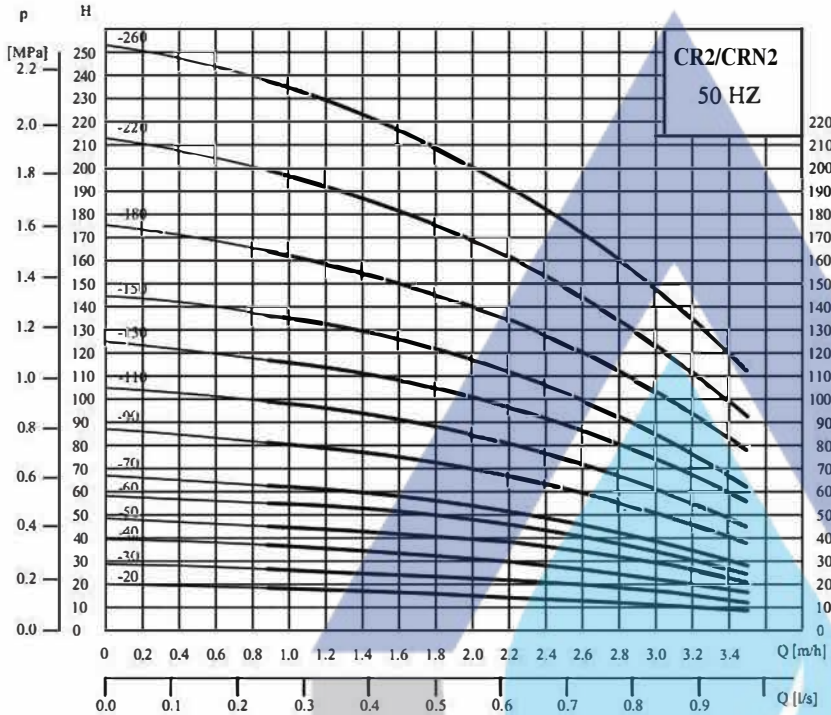

Dimensions and weights

pump type	DIMENSIONS [mm]						Net Weight [kg]	
	* B1	B2	* B1+B2	** B1	** B1+B2	D1	D2	* **
CR2-20	220	190	410	245	435	140	110	20 25
CR2-30	240	190	430	265	455	140	110	20 25
CR2-40	260	190	450	285	475	140	110	20 25
CR2-50	275	190	465	300	490	140	110	20 25
CR2-60	300	230	530	325	555	140	110	20 25
CR2-70	315	230	545	340	570	140	110	25 30
CR2-90	350	230	580	375	605	140	110	30 35
CR2-110	385	230	615	410	640	140	110	30 35
CR2-130	440	280	720	465	745	180	110	30 35
CR2-150	475	280	755	500	780	180	110	30 35
CR2-180		280		555	835	180	110	50
CR2-220		280		625	905	180	110	55
CR2-260		335		705	1040	180	110	60

* CR2 With Oval flanges
 ** CR2 With DIN flanges
 Pipework connection
 DIN 2566 with threaded socket
 DIN/2634/2635 with socket for welding
 * Oval flange base for pump models CR2-20 to CR2-260
 ** DIN flange base for pump models CR2-20 to CR2-260

Materials CR2 /CR12

POS. NO.	Description	Materials	DIN W.-NO	AISI / ASTM
1	Pump head	Cast iron GG20	0.6020	ASTM 25B
* 2	Cupling guard	stainless steel	1.4301	AISI 304
3	shaft	stainless steel	1.4401 1.4057	AISI 316 AISI 431
* 4	impeller	stainless steel	1.4301	AISI 304
* 5	intermediate chamber	stainless steel	1.4301	AISI 304
* 6	Outer sleeve	stainless steel	1.4301	AISI 304
	Stay bolts	stainless steel or steel 50	1.4057 1.0531	AISI 431
* 7	Base	Cast iron GG20	0.6020	ASTM 25B
8	Neck ring	Teflon		
9	shaft seal	Tungesten carbide Silicon carbide		
	Rubber parts in pump	EPDM or FPM (viton)		

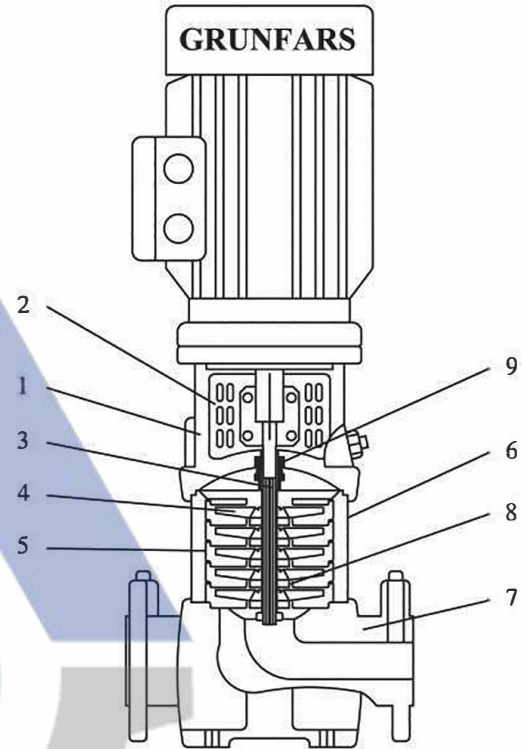

Material for Position No. Marked * in CR2 Type is -Stainless Steel (1.4401 AISI 316)

Electrical Data

pump type	Motor		Full load current I 1/1 [A]	Power Factor Cosφ 1/1	Motor Efficiency n [%]	$\frac{I_{start}}{I_{1/1}}$
	[KW]	[hp]				
CR2-20	0.37	0.5	0.96	0.84-0.76	72	4.8-5.2
CR2-30	0.37	0.5	0.96	0.84-0.76	72	4.8-5.2
CR2-40	0.55	0.75	1.44	0.84-0.76	72	4.8-5.2
CR2-50	0.55	0.75	1.44	0.84-0.76	72	4.8-5.2
CR2-60	0.75	1.0	1.86	0.86-0.78	74	5.0-5.5
CR2-70	0.75	1.0	1.86	0.86-0.78	74	5.0-5.5
CR2-90	1.1	1.5	2.65	0.87-0.79	76	5.2-5.7
CR2-110	1.1	1.5	2.65	0.87-0.79	76	5.2-5.7
CR2-130	1.5	2.0	3.4	0.85-0.79	82	6.3-6.9
CR2-150	1.5	2.0	3.4	0.85-0.79	82	6.3-6.9
CR2-180	2.2	3.0	4.75	0.87-0.82	84	7.0-7.5
CR2-220	2.2	3.0	4.75	0.87-0.82	84	7.0-7.5
CR2-260	3.0	4.0	6.25	0.88-0.82	86	7.8-8.5

Single phase motors 1×240 v, 50HZ

Motor rating	Full load current amps	Locked Rotor Current Ratio
0.37 kw	3.8	4.0
0.55 kw	5.2	4.2
0.75 kw	6.2	4.0
1.1 kw	7.5	5.2
1.5 kw	9.5	6.0
2.2 kw	14.5	5.0

Motors : Eenclosure clas IP55
Standard 50HZ voltages available:
3x220-240/380-415 V-motors up to 3kw
3x380-415V-motors from 4kw and upwards
1x240V-motors up to 2.2kw
Motors for other voltages available on request
All motors must be connected to a motor starter-
in accordance with local regulations

Midd, East

GRUNFARS

Pumps

CR3 & CRI3 SERIES





Performance curves

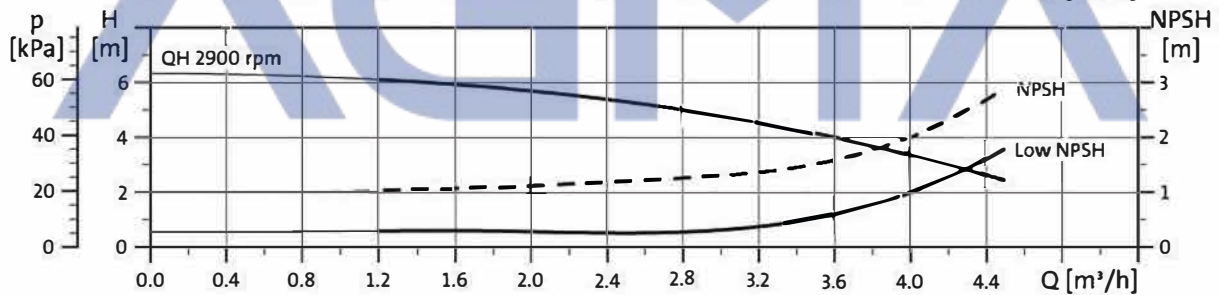
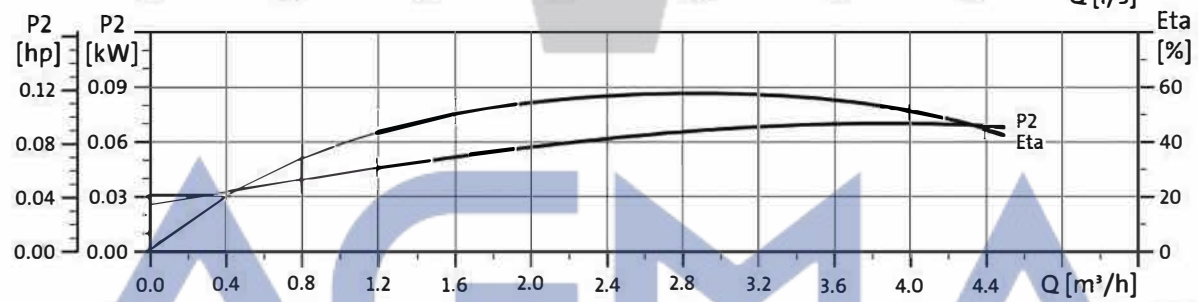
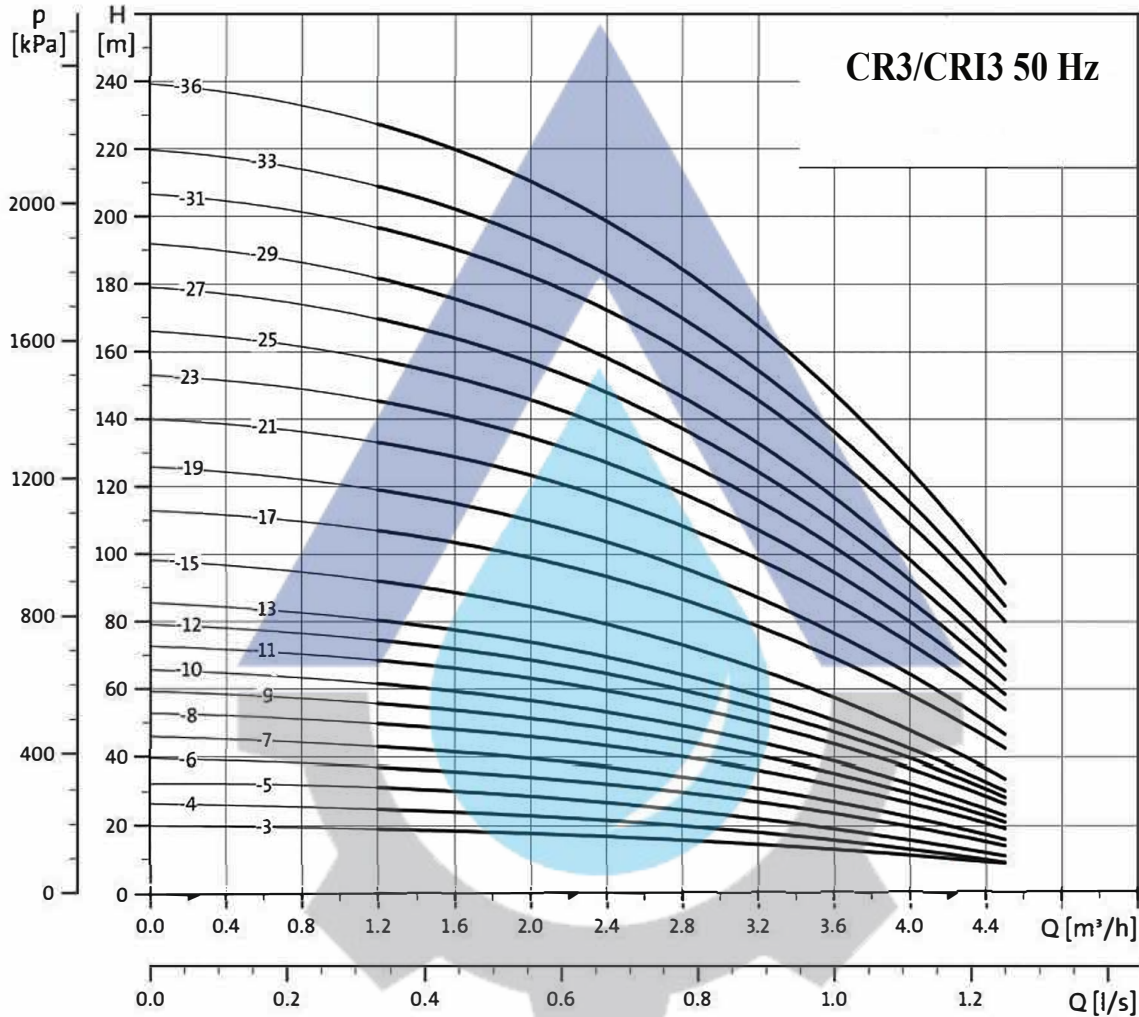



Materials CR3/CRI3

POS. NO.	Description	Materials	DIN W.-NO	AISI / ASTM
1	Pump head	Cast iron GG20	0.6020	ASTM 25B
* 2	Cupling guard	stainless steel	1.4301	AISI 304
3	shaft	stainless steel	1.4401 1.4057	AISI 316 AISI 431
* 4	impeller	stainless steel	1.4301	AISI 304
* 5	intermediate chamber	stainless steel	1.4301	AISI 304
* 6	Outer sleeve	stainless steel	1.4301	AISI 304
	Stay bolts	stainless steel or steel 50	1.4057 1.0531	AISI 431
* 7	Base	Cast iron GG20	0.6020	ASTM 25B
8	Neck ring	Teflon		
9	shaft seal	Tungesten carbide Silicon carbide		
	Rubber parts in pump	EPDM or FPM (viton)		

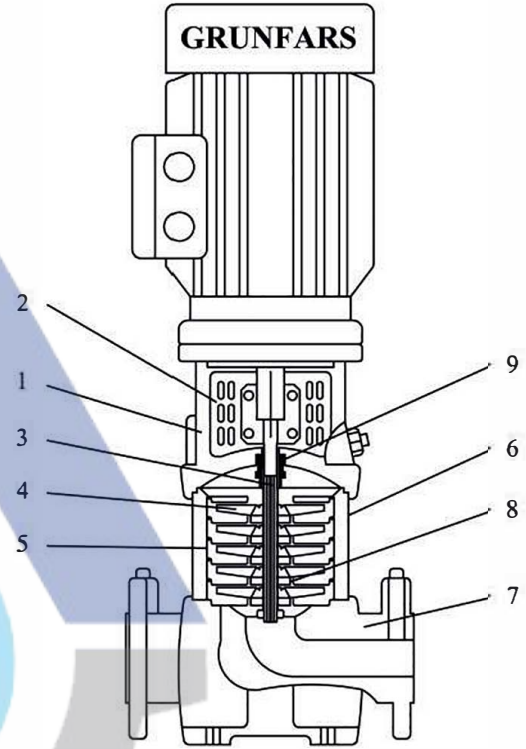

Material for Position No. Marked * in CRI
Stainless Steel (1.4401 AISI 316)

Type is -

Electrical Data

pump type	Motor		Full load current I _l /I [A]	Power Factor Cosφ 1/1	Motor Efficiency η [%]	$\frac{I_{start}}{I_{l}}$
	[KW]	[hp]				
CR3-3	0.37	0.5	0.96	0.84-0.76	72	4.8-5.2
CR3-4	0.37	0.5	0.96	0.84-0.76	72	4.8-5.2
CR3-5	0.37	0.5	0.96	0.84-0.76	72	4.8-5.2
CR3-6	0.55	0.75	1.44	0.84-0.76	72	4.8-5.2
CR3-7	0.55	0.75	1.44	0.84-0.76	72	4.8-5.2
CR3-8	0.75	1.0	1.86	0.86-0.78	74	5.0-5.5
CR3-9	0.75	1.0	1.86	0.84-0.76	74	5.0-5.5
CR3-10	0.75	1.0	1.86	0.86-0.78	74	5.0-5.5
CR3-11	1.1	1.5	2.65	0.87-0.79	76	5.2-5.7
CR3-12	1.1	1.5	2.65	0.87-0.79	76	5.2-5.7
CR3-13	1.1	1.5	2.65	0.87-0.79	76	5.2-5.7
CR3-15	1.1	1.5	2.65	0.87-0.79	76	5.2-5.7
CR3-17	1.5	2.0	3.4	0.85-0.79	82	6.3-6.9
CR3-19	1.5	2.0	3.4	0.85-0.79	82	6.3-6.9
CR3-21	2.2	3.0	4.75	0.87-0.82	84	7.0-7.6
CR3-23	2.2	3.0	4.75	0.87-0.82	84	7.0-7.6
CR3-25	2.2	3.0	4.75	0.87-0.82	84	7.0-7.6
CR3-27	2.2	3.0	4.75	0.87-0.82	84	7.0-7.6
CR3-29	2.2	3.0	4.75	0.87-0.82	84	7.0-7.6
CR3-31	3.0	4.0	6.25	0.88-0.82	86	7.8-8.5
CR3-33	3.0	4.0	6.25	0.88-0.82	86	7.8-8.5
CR3-36	3.0	4.0	6.25	0.88-0.82	86	7.8-8.5

Midd, East

GRUNFARS

Pumps

CR4 & CRI4 SERIES





CR4 / CRI4

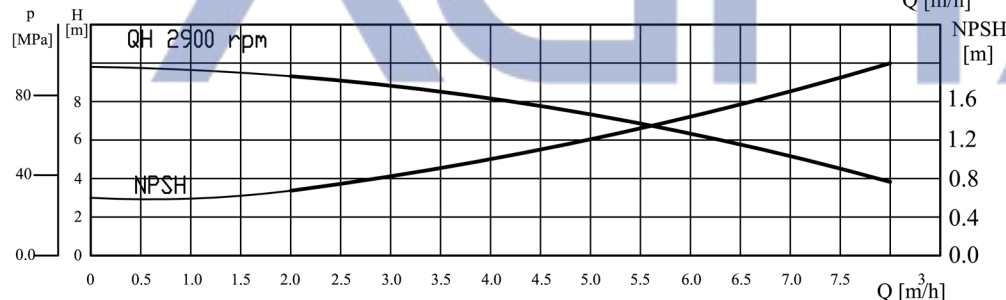
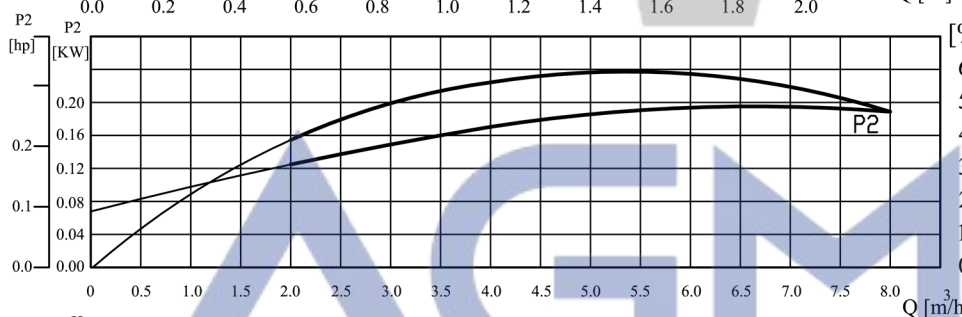
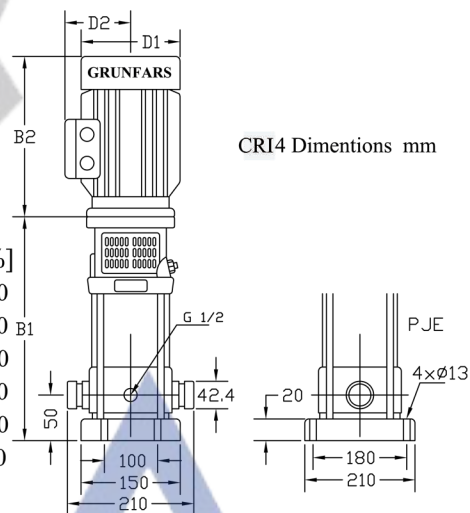
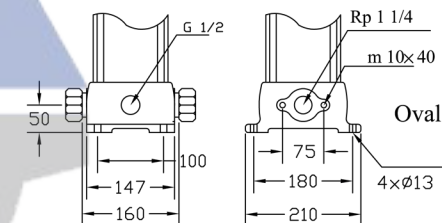
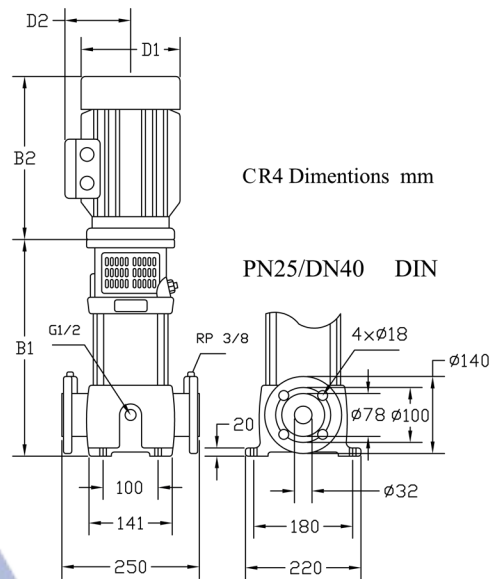
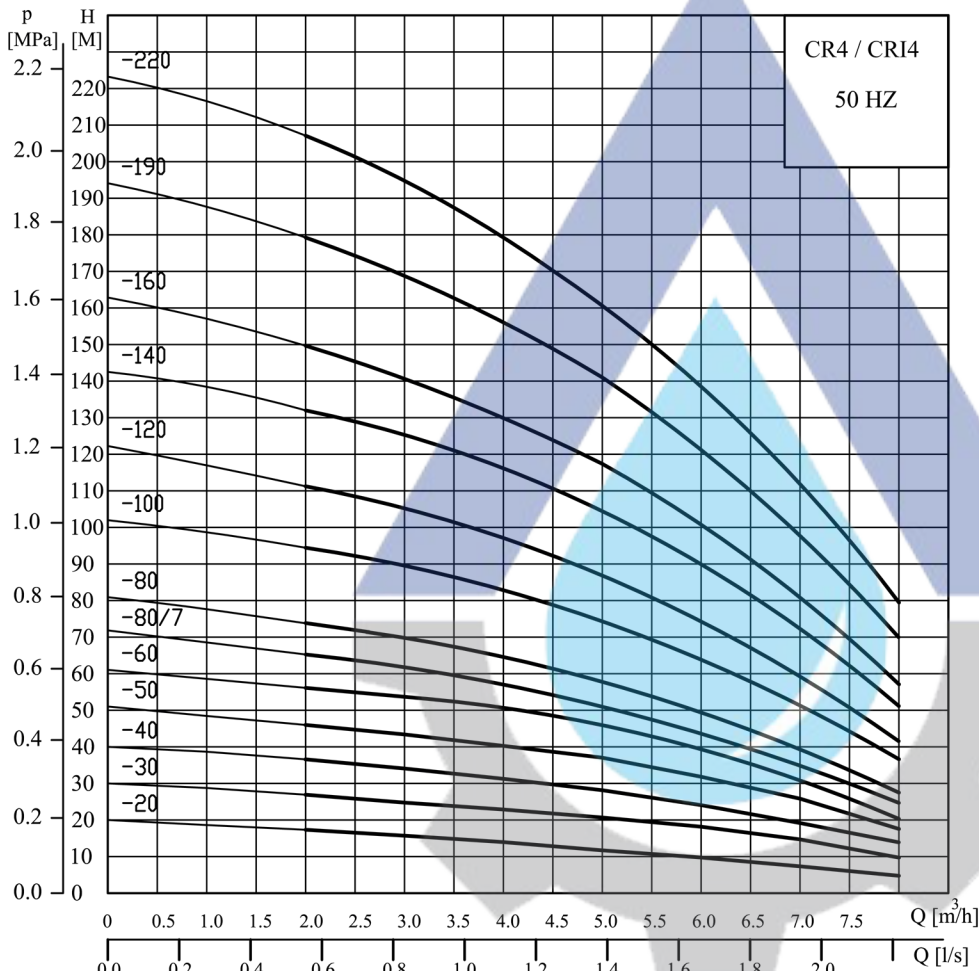

Dimensions and weights

pump type	Dimensions [mm]						Net Weight [kg]	
	* B1	B2	* B1+B2	** B1	** B1+B2	D1	D2	* **
CR4-20	235	190	425	260	450	140	110	20 25
CR4-30	265	190	455	290	480	140	110	20 25
CR4-40	295	230	525	320	550	140	110	20 25
CR4-50	325	230	555	350	580	140	110	20 25
CR4-60	350	230	580	375	605	140	110	20 25
CR4-70	420	280	700	445	720	180	125	25 30
CR4-80	420	280	700	445	725	180	110	25 30
CR4-100	475	280	755	500	780	180	110	30 35
CR4-120	530	280	810	555	835	180	110	30 35
CR4-140	645	335	980	670	1005	180	110	40 45
CR4-160	645	335	980	670	1005	180	110	40 45
CR4-190		370		750	1080	180	135	60
CR4-220		370		830	1200	180	135	65

* CR4 With DIN flanges
** CR4 With Oval flanges

Pipework connection
DIN 2566 with threaded socket
DIN/2634/2635 with socket for welding

* Oval flange base for pump models CR4-20/1 to CR4-160
** DIN flange base for pump models CR4-20/1 to CR4-220

Materials CR4 / CRI4

POS. NO.	Description	Materials	DIN W.-NO	AISI / ASTM
1	Pump head	Cast iron GG20	0.6020	ASTM 25B
* 2	Cupling guard	stainless steel	1.4301	AISI 304
3	shaft	stainless steel	1.4401 1.4057	AISI 316 AISI 431
* 4	impeller	stainless steel	1.4301	AISI 304
* 5	intermediate chamber	stainless steel	1.4301	AISI 304
* 6	Outer sleeve	stainless steel	1.4301	AISI 304
	Stay bolts	stainless steel or steel 50	1.4057 1.0531	AISI 431
* 7	Base	Cast iron GG20	0.6020	ASTM 25B
8	Neck ring	Teflon		
9	shaft seal	Tungesten carbide Silicon carbide		
	Rubber parts in pump	EPDM or FPM (viton)		

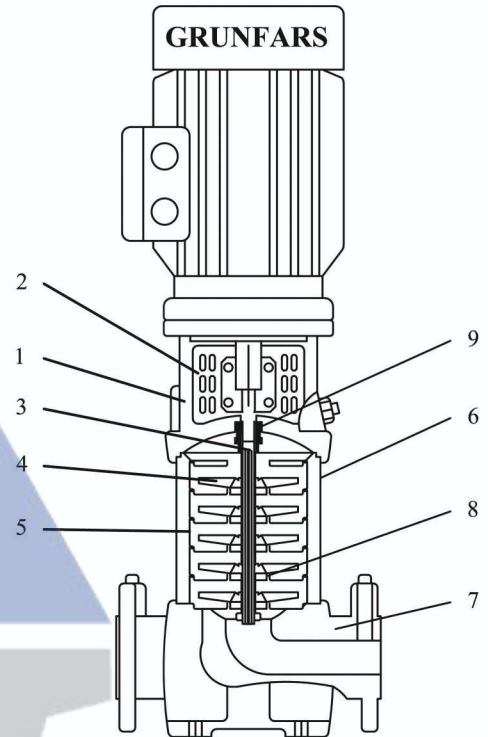

Material for Position No. Marked * in CRI Type is -
Stainless Steel (1.4401 AISI 316)

Electrical Data

pump type	Motor		Full load current I _{1/1} [A]	Power Factor Cosφ 1/1	Motor Efficiency η [%]	$\frac{I_{start}}{I_{1/1}}$
	[KW]	[hp]				
CR4-20	0.37	0.5	0.96	0.84-0.76	72	4.8-5.2
CR4-30	0.55	0.75	1.44	0.84-0.76	72	4.8-5.2
CR4-40	0.75	1.0	1.86	0.86-0.78	74	5.0-5.5
CR4-50	1.1	1.5	2.65	0.87-0.79	76	5.2-5.7
CR4-60	1.1	1.5	2.65	0.87-0.79	76	5.2-5.7
CR4-70	1.5	2.0	3.4	0.85-0.79	82	6.3-6.9
CR4-80	1.5	2.0	3.4	0.85-0.79	82	6.3-6.9
CR4-100	2.2	3.0	4.75	0.87-0.82	84	7.0-7.5
CR4-120	2.2	3.0	4.75	0.87-0.82	84	7.0-7.5
CR4-140	3.0	4.0	6.25	0.88-0.82	86	7.8-8.5
CR4-160	3.0	4.0	6.25	0.88-0.82	86	7.8-8.5
CR4-190	4.0	5.5	8.00	0.90-0.87	87	8.7-9.5
CR4-220	4.0	5.5	8.00	0.90-0.87	87	8.7-9.5

Single phase motors 1x240 v, 50HZ

Motor rating	Full load current amps	Locked Rotor Current Ratio
0.37 kw	3.8	4.0
0.55 kw	5.2	4.2
0.75 kw	6.2	4.0
1.1 kw	7.5	5.2
1.5 kw	9.5	6.0
2.2 kw	14.5	5.0

Motors : Eenclosure clas IP55
Standard 50HZ voltages available:
3x220-240/380-415 V-motors up to 3kw
3x380-415V-motors from 4kw and upwards
1x240V-motors up to 2.2kw
Motors for other voltages available on request
All motors must be connected to a motor starter-
in accordance with local regulations

Midd, East

GRUNFARS

Pumps

CR5 & CRI5 SERIES





CR5 / CR15

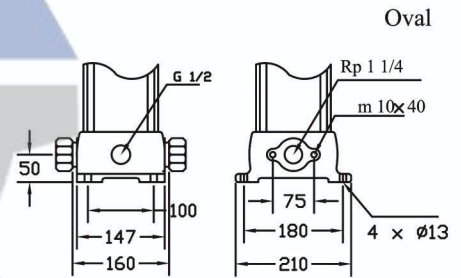
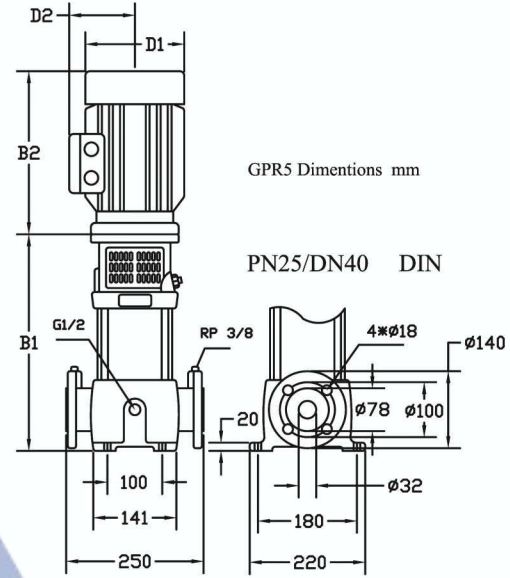
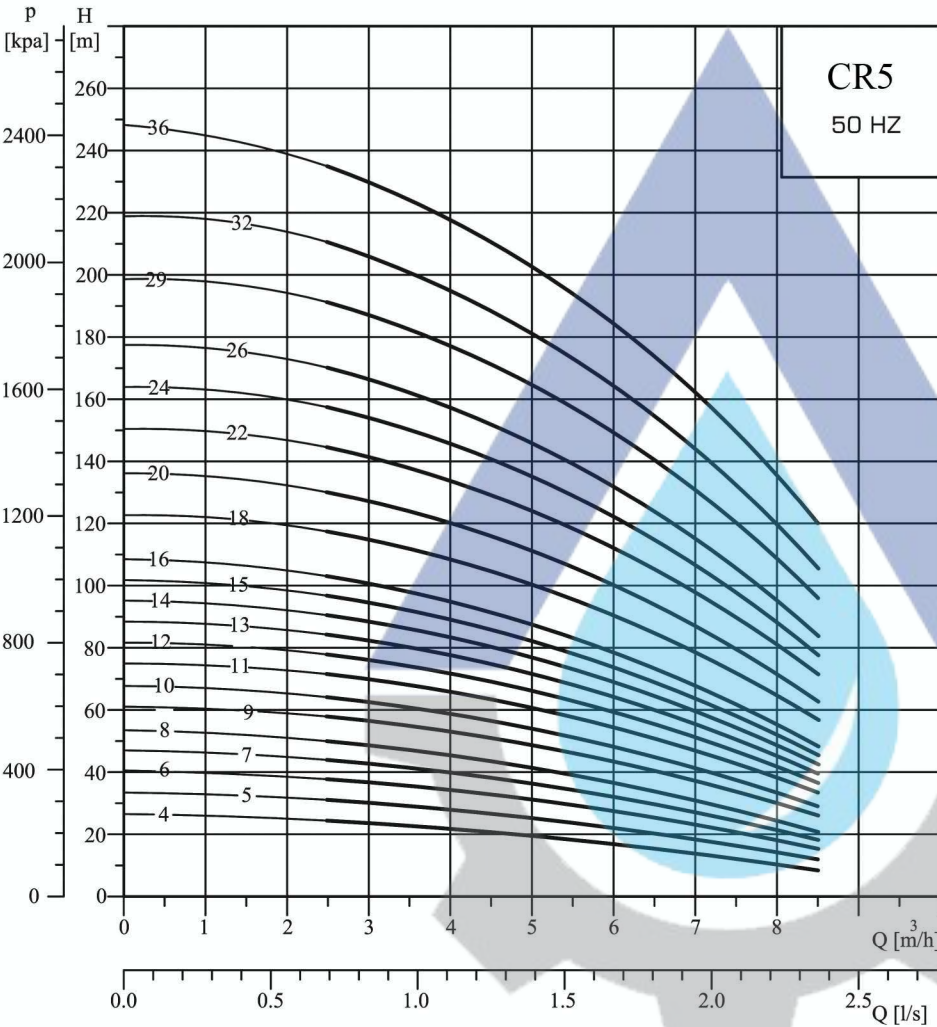

Dimensions and weights

pump type	Dimensions [mm]						Net Weight [kg]		
	B1	B2	* B1+B2	** B1	** B1+B2	D1	D2	*	**
CR5-4	310	191	501	335	526	141	109	19.7	23.8
CR5-5	341	231	572	366	597	141	109	22.6	26.7
CR5-6	368	231	599	393	624	141	109	24.6	28.7
CR5-7	395	231	626	420	651	141	109	25.3	29.4
CR5-8	422	231	653	447	678	141	109	26.1	30.2
CR5-9	465	281	746	490	771	178	110	32.4	36.5
CR5-10	492	281	773	517	798	178	110	32.8	36.9
CR5-11	519	281	800	544	825	178	110	35.1	39.2
CR5-12	546	281	827	571	852	178	110	35.5	39.6
CR5-13	573	281	854	598	879	178	110	36.1	40.2
CR5-14	600	281	881	625	906	178	110	36.8	40.9
CR5-15	627	281	908	652	933	178	110	37.4	41.5
CR5-16	654	281	935	679	960	178	110	38.0	42.1
CR5-18	712	335	1047	737	1072	178	110	44.8	48.9
CR5-20	766	335	1101	791	1126	178	110	46.1	50.2
CR5-22	820	372	1192	845	1217	220	134	55.8	59.9
CR5-24	-	372	-	899	1271	220	134	-	62.0
CR5-26	-	372	-	953	1325	220	134	-	63.3
CR5-29	-	372	-	1034	1406	220	134	-	65.2
CR5-32	-	391	-	1145	1536	220	134	-	80.0
CR5-36	-	391	-	1253	1644	220	134	-	82.6

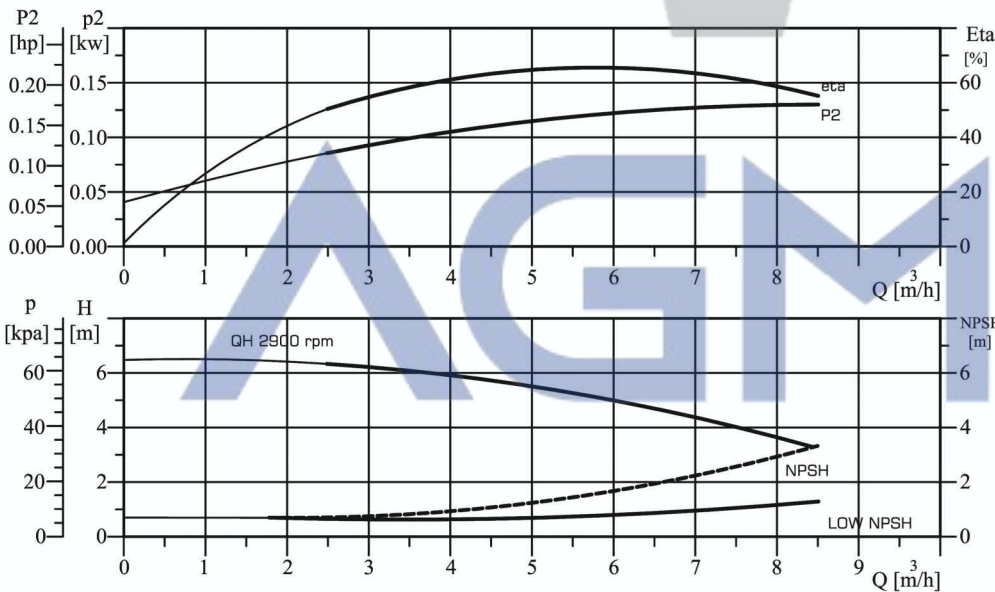

* CR5 With Oval flanges
 ** CR5 With DIN flanges

Pipework connection
 DIN 2566 with threaded socket
 DIN/2634/2635 with socket for welding

* Oval flange base for pump models CR5-4 to CR5-22
 ** DIN flange base for pump models CR5-4 to CR5-36



Materials CR5 / CRI5

POS. NO.	Description	Materials	DIN W.-NO	AISI / ASTM
1	Pump head	Cast iron GG20	0.6020	ASTM 25B
* 2	Cupling guard	stainless steel	1.4301	AISI 304
3	shaft	stainless steel	1.4401 1.4057	AISI 316 AISI 431
* 4	impeller	stainless steel	1.4301	AISI 304
* 5	intermediate chamber	stainless steel	1.4301	AISI 304
* 6	Outer sleeve	stainless steel	1.4301	AISI 304
	Stay bolts	stainless steel or steel 50	1.4057 1.0531	AISI 431
* 7	Base	Cast iron GG20	0.6020	ASTM 25B
8	Neck ring	Teflon		
9	shaft seal	Tungsten carbide Silicon carbide		
	Rubber parts in pump	EPDM or FPM (viton)		

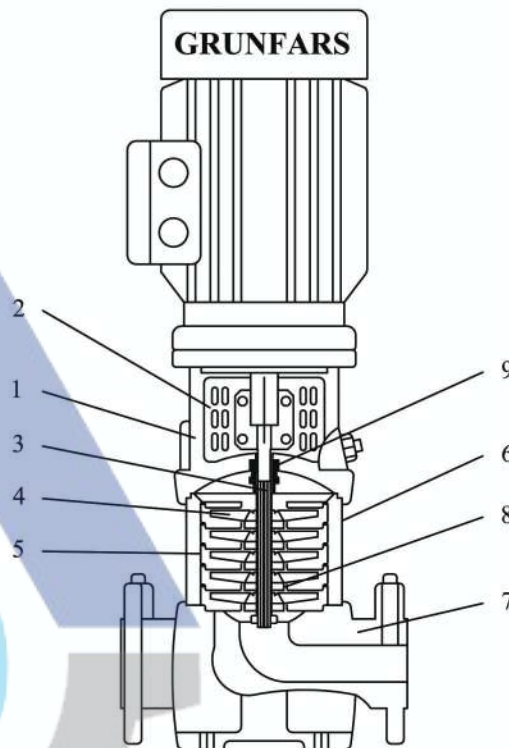

Material for Position No. Marked * in GPRN Type is -
Stainless Steel (1.4401 AISI 316)

Electrical Data

pump type	Motor		Full load current I _l [A]	Power Factor Cosφ 1/1	Motor Efficiency η [%]	I _{start} I _l / 1
	[KW]	[hp]				
CR5-4	0.75	1.0	1.86	0.86-0.78	74	5.0-5.5
CR5-5	0.75	1.0	1.86	0.84-0.76	74	5.0-5.5
CR5-6	1.1	1.5	2.65	0.87-0.79	76	5.2-5.7
CR5-7	1.1	1.5	2.65	0.87-0.79	76	5.2-5.7
CR5-8	1.1	1.5	2.65	0.87-0.79	76	5.2-5.7
CR5-9	1.5	2.0	3.4	0.85-0.79	82	6.3-6.9
CR5-10	1.5	2.0	3.4	0.85-0.79	82	6.3-6.9
CR5-11	2.2	3.0	4.75	0.87-0.82	84	7.0-7.6
CR5-12	2.2	3.0	4.75	0.87-0.82	84	7.0-7.6
CR5-13	2.2	3.0	4.75	0.87-0.82	84	7.0-7.6
CR5-14	2.2	3.0	4.75	0.87-0.82	84	7.0-7.6
CR5-15	2.2	3.0	4.75	0.87-0.82	84	7.0-7.6
CR5-16	2.2	3.0	4.75	0.87-0.82	84	7.0-7.6
CR5-18	3.0	4.0	6.25	0.88-0.82	86	7.8-8.5
CR5-20	3.0	4.0	6.25	0.88-0.82	86	7.8-8.5
CR5-22	4.0	5.5	8.00	0.90-0.87	87	8.7-9.5
CR5-24	4.0	5.5	8.00	0.90-0.87	87	8.7-9.5
CR5-26	4.0	5.5	8.00	0.90-0.87	87	8.7-9.5
CR5-29	4.0	5.5	8.00	0.90-0.87	87	8.7-9.5
CR5-32	5.5	7.5	11.0	0.89-0.86	88.5	8.9-9.7
CR5-36	5.5	7.5	11.0	0.89-0.86	88.5	8.9-9.7

Midd, East

GRUNFARS

Pumps

CR8 & CR18 SERIES



CR8 /CRI8

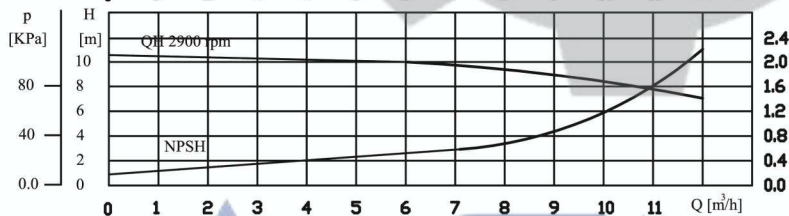
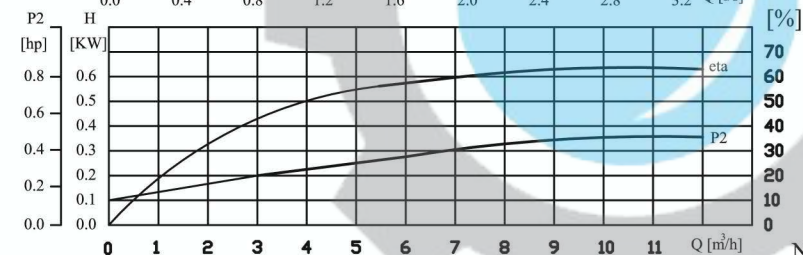
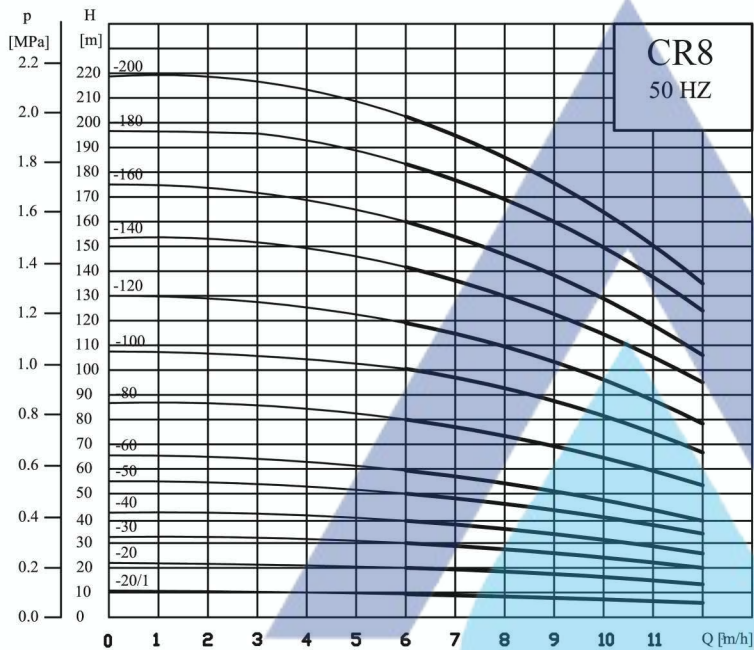

Dimensions and weights

pump type	DIMENSIONS [mm]						Net Weight [kg]	
	B1	B2	B1+B2	D1	D2	D3	*	**
CR8-20/1	355	190	525	140	110		30	35
CR8-20	340	230	570	140	110		30	35
CR8-30	370	230	600	140	110		30	35
CR8-40	415	280	695	180	110		40	45
CR8-50	445	280	725	180	110		45	50
CR8-60	475	280	755	180	110		45	50
CR8-80	540	335	875	180	110		50	55
CR8-100	600	370	970	180	135		50	55
CR8-120	660	370	1030	180	135		55	60
CR8-140	740	390	1130	220	135	300		85
CR8-160	800	390	1190	220	135	300		85
CR8-180	860	390	1250	220	135	300		90
CR8-200	920	390	1310	220	135	300		90

* CR8 With Oval flanges

** CR8 With DIN flanges

Pipework connection

DIN 2566 with threaded socket

DIN/2634/2635 with socket for welding

* Oval flange base for pump modes CR8-20 to CR8-80

** DIN flange base for pump modes CR8-80 to CR8-200

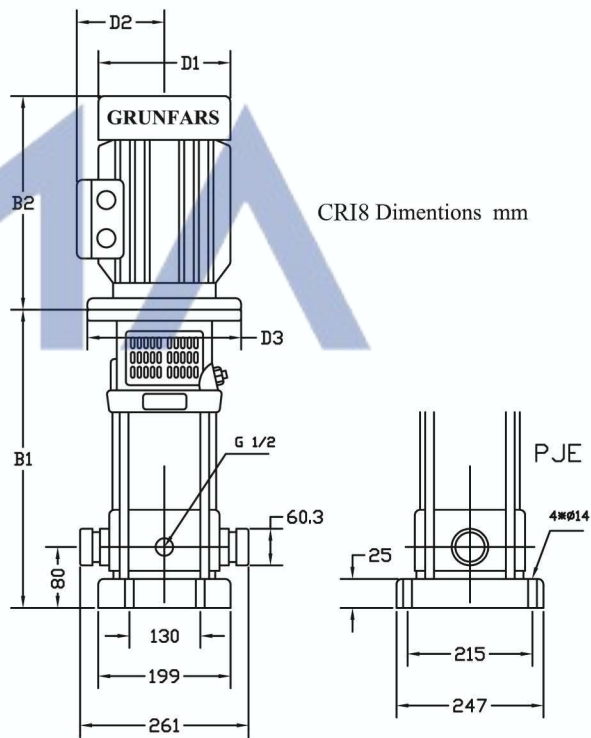
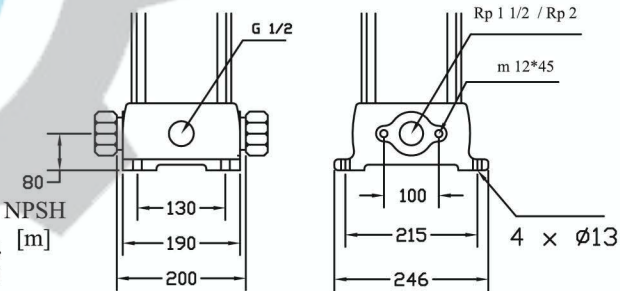
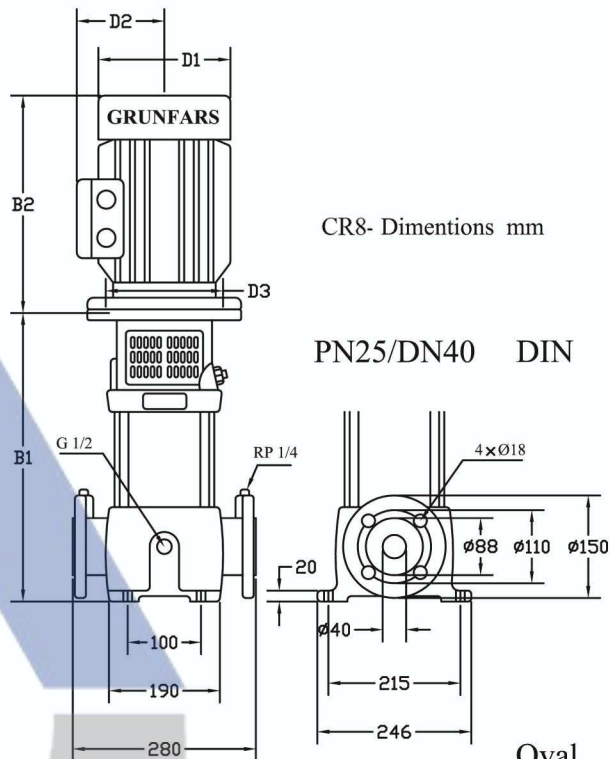



Materials CR8 / CRI8

POS. NO.	Description	Materials	DIN W.-NO	AISI / ASTM
1	Pump head	Cast iron GG20	0.6020	ASTM 25B
* 2	Cupling guard	stainless steel	1.4301	AISI 304
3	shaft	stainless steel	1.4401 1.4057	AISI 316 AISI 431
* 4	impeller	stainless steel	1.4301	AISI 304
* 5	intermediate chamber	stainless steel	1.4301	AISI 304
* 6	Outer sleeve	stainless steel	1.4301	AISI 304
	Stay bolts	stainless steel or steel 50	1.4057 1.0531	AISI 431
* 7	Base	Cast iron GG20	0.6020	ASTM 25B
8	Neck ring	Teflon		
9	shaft seal	Tungesten carbide Silicon carbide		
	Rubber parts in pump	EPDM or FPM (viton)		

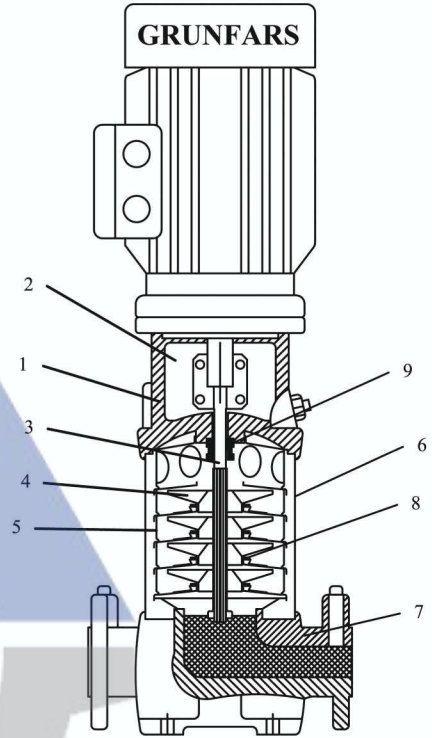

Material for Position No. Marked * in GPRN Type is -
Stainless Steel (1.4401 AISI 316)

Electrical Data

3 X 380-415 V , 50 HZ

pump type	Motor		Full load current I _{1/1} [A]	Power Factor Cosφ 1/1	Motor Efficiency n [%]	$\frac{I_{start}}{I_{1/1}}$
	[KW]	[hp]				
CR8-20/1	0.37	0.5	0.96	0.84-0.76	72	4.8-5.2
CR8-20	0.75	1.0	1.86	0.86-0.78	74	5.0-5.5
CR8-30	1.1	1.5	2.65	0.87-0.79	76	5.2-5.7
CR8-40	1.5	2.0	3.4	0.85-0.79	82	6.3-6.9
CR8-50	2.2	3.0	4.75	0.87-0.82	84	7.0-7.6
CR8-60	2.2	3.0	4.75	0.87-0.82	84	7.0-7.6
CR8-80	3.0	4.0	6.25	0.88-0.82	86	7.8-8.5
CR8-100	4.0	5.5	8.00	0.90-0.87	87	8.7-9.5
CR8-120	4.0	5.5	8.00	0.90-0.87	87	8.7-9.5
CR8-140	5.5	7.5	11.0	0.89-0.86	88.5	8.9-9.7
CR8-160	5.5	7.5	11.0	0.89-0.86	88.5	8.9-9.7
CR8-180	7.5	10	15.2	0.87-0.81	89	9.1-9.9
CR8-200	7.5	10	15.2	0.87-0.81	89	9.1-9.9

Single phase motors 1x240 v, 50HZ

Motor rating	Full load current amps	Locked Rotor Current Ratio
0.37 kw	3.8	4.0
0.55 kw	5.2	4.2
0.75 kw	6.2	4.0
1.1 kw	7.5	5.2
1.5 kw	9.5	6.0
2.2 kw	14.5	5.0

Motors : Eenclosure clas IP55
Standard 50HZ voltages available:
3x220-240/380-415 V-motors up to 3kw
3x380-415V-motors from 4kw and upwards
1x240V-motors up to 2.2kw
Motors for other voltages available on request
All motors must be connected to a motor starter-
in accordance with local regulations

Midd, East

GRUNFARS

Pumps



CR10 & CRI10 SERIES



AGM



CR10 / CRI10

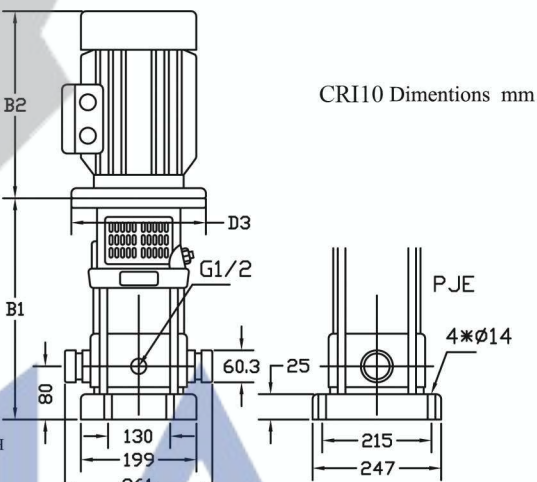
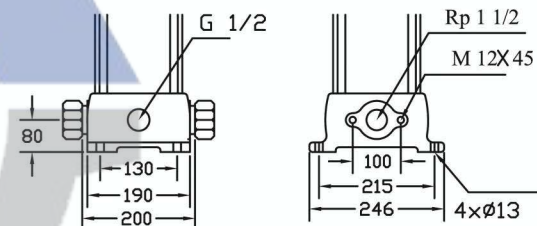
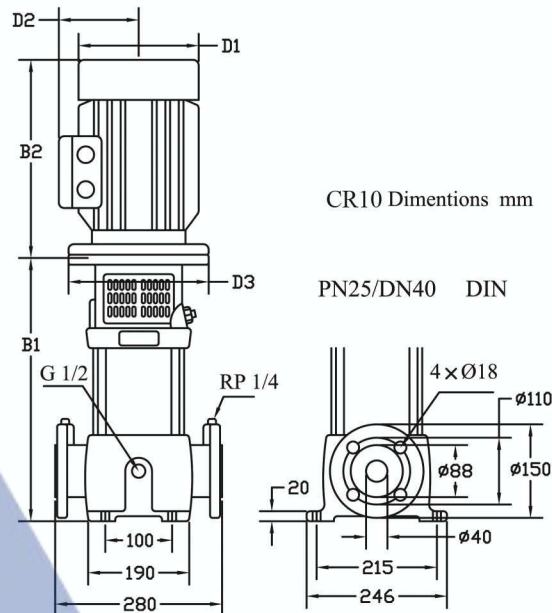
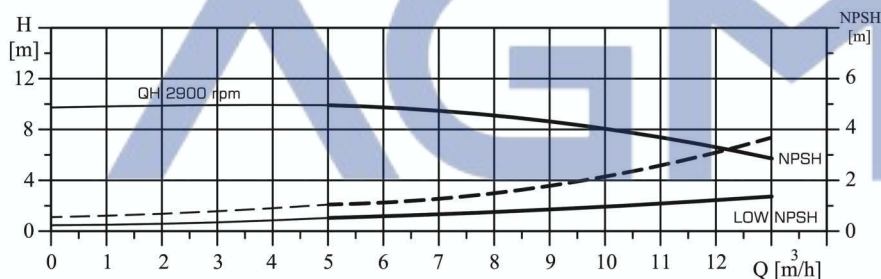
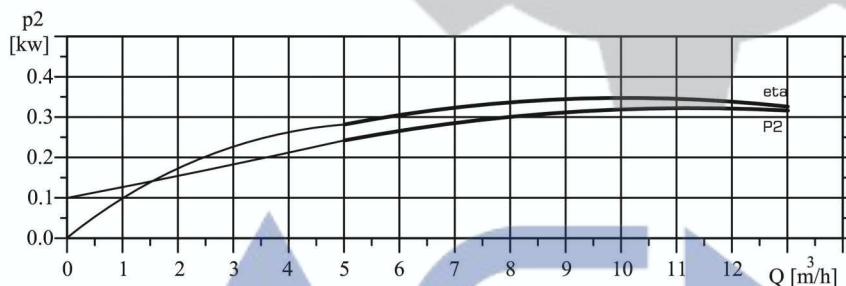
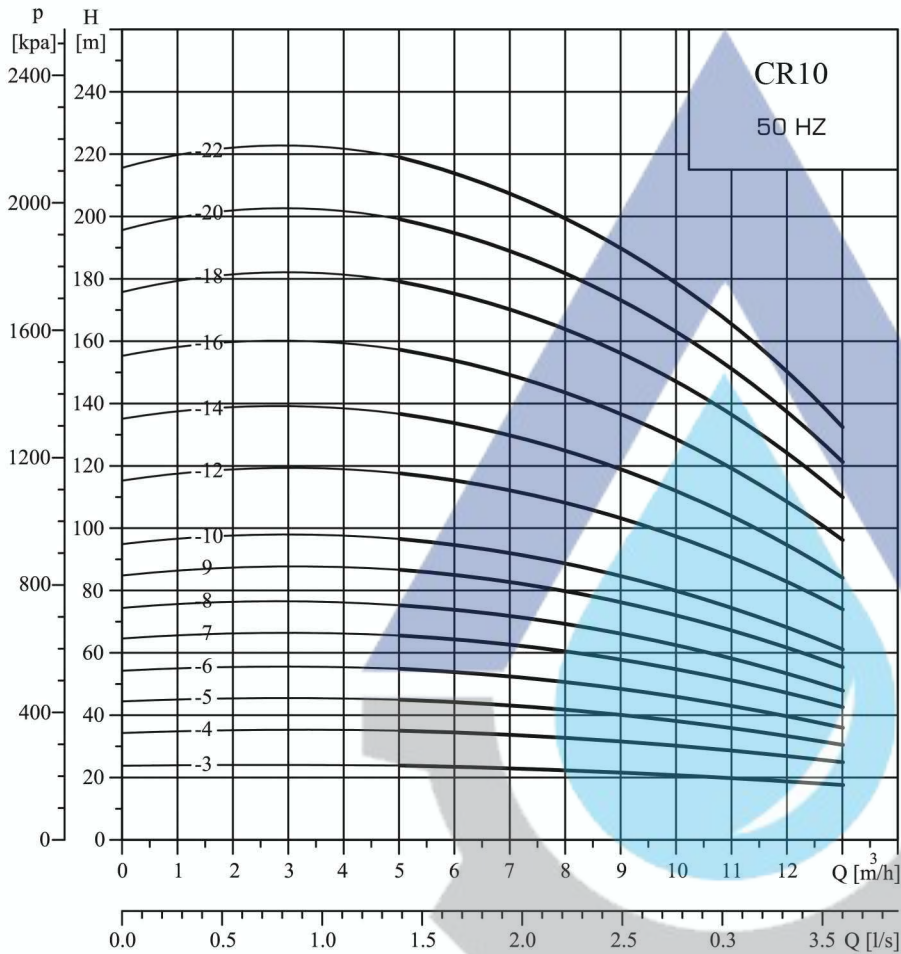

Dimintions and weights

pump type	Dimintions [mm]							Net Weight [kg]		
	B1	B2	B1+B2	B1	B1+B2	D1	D2	D3	*	**
CR10-3	423	231	654	423	654	141	110	-	37	40
CR10-4	423	231	704	423	704	178	110	-	43	46
CR10-5	453	281	734	453	734	178	110	-	46	49
CR10-6	483	281	764	483	764	178	110	-	47	50
CR10-7	518	335	853	518	853	178	110	-	52	55
CR10-8	548	335	883	548	883	178	110	-	53	56
CR10-9	578	372	950	578	950	220	134	-	65	68
CR10-10	608	372	980	608	980	220	134	-	65	68
CR10-12	668	372	1040	668	1040	220	134	-	67	70
CR10-14	760	391	1151	760	1151	220	134	300	90	93
CR10-16	820	391	1211	820	1211	220	134	300	92	95
CR10-18	-	-	-	880	1271	220	134	300	-	100
CR10-20	-	-	-	940	1331	220	134	300	-	103
CR10-22	-	-	-	1000	1391	220	134	300	-	105

* CR10 With Oval flanges

** CRI10 With DIN flanges

Pipework connection

DIN 2566 with threaded socket

DIN/2634/2635 with socket for welding

* Oval flange base for pump modes CR10-3 to CR10-16

** DIN flange base for pump modes CR10-3 to CR10-22



Materials CR10 / CRI10

POS. NO.	Description	Materials	DIN W.-NO	AISI / ASTM
1	Pump head	Cast iron GG20	0.6020	ASTM 25B
* 2	Cupling guard	stainless steel	1.4301	AISI 304
3	shaft	stainless steel	1.4401 1.4057	AISI 316 AISI 431
* 4	impeller	stainless steel	1.4301	AISI 304
* 5	intermediate chamber	stainless steel	1.4301	AISI 304
* 6	Outer sleeve	stainless steel	1.4301	AISI 304
	Stay bolts	stainless steel or steel 50	1.4057 1.0531	AISI 431
* 7	Base	Cast iron GG20	0.6020	ASTM 25B
8	Neck ring	Teflon		
9	shaft seal	Tungesten carbide Silicon carbide		
	Rubber parts in pump	EPDM or FPM (viton)		

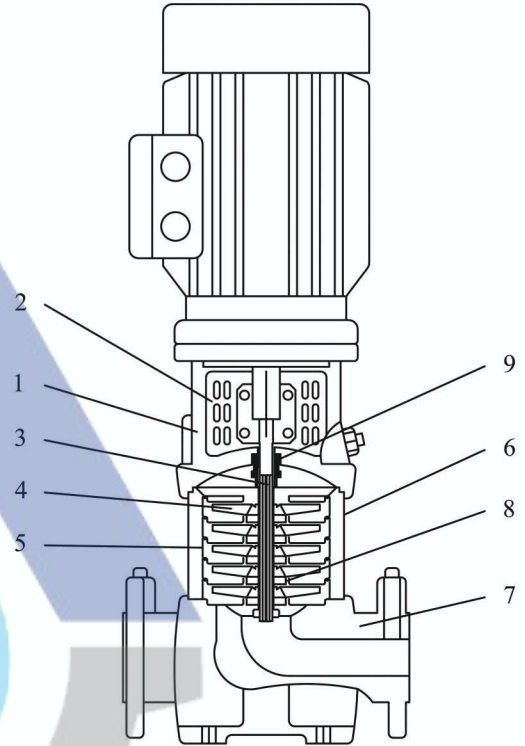

Material for Position No. Marked * in CRN Type is -
Stainless Steel (1.4401 AISI 316)

Electrical Data

pump type	Motor		Full load current I _{1/1} [A]	Power Factor Cosφ 1/1	Motor Efficiency η [%]	$\frac{I_{start}}{I_{1/1}}$
	[KW]	[hp]				
CR10-3	1.1	1.5	2.65	0.87-0.79	76	5.2-5.7
CR10-4	1.5	2.0	3.4	0.85-0.79	82	6.3-6.9
CR10-5	2.2	3.0	4.75	0.87-0.82	84	7.0-7.6
CR10-6	2.2	3.0	4.75	0.87-0.82	84	7.0-7.6
CR10-7	3.0	4.0	6.25	0.88-0.82	86	7.8-8.5
CR10-8	3.0	4.0	6.25	0.88-0.82	86	7.8-8.5
CR10-9	4.0	5.5	8.00	0.90-0.87	87	8.7-9.5
CR10-10	4.0	5.5	8.00	0.90-0.87	87	8.7-9.5
CR10-12	4.0	5.5	8.00	0.90-0.87	87	8.7-9.5
CR10-14	5.5	7.5	11.0	0.89-0.86	88.5	8.9-9.7
CR10-16	5.5	7.5	11.0	0.89-0.86	88.5	8.9-9.7
CR10-18	7.5	10	15.2	0.87-0.81	89	9.1-9.9
CR10-20	7.5	10	15.2	0.87-0.81	89	9.1-9.9
CR10-22	7.5	10	15.2	0.87-0.81	89	9.1-9.9

Midd, East

GRUNFARS

Pumps



CR15 & CRI15 SERIES



AGMA

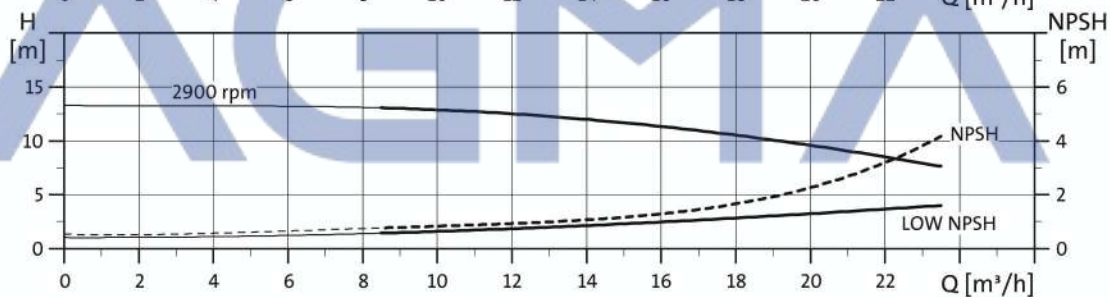
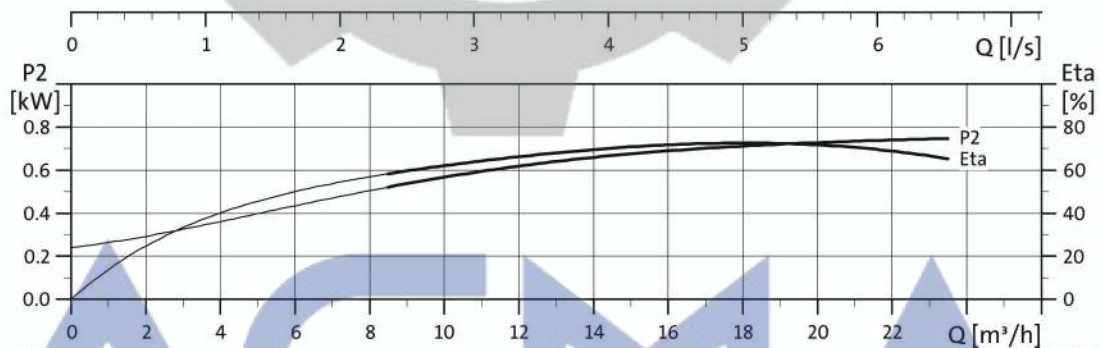
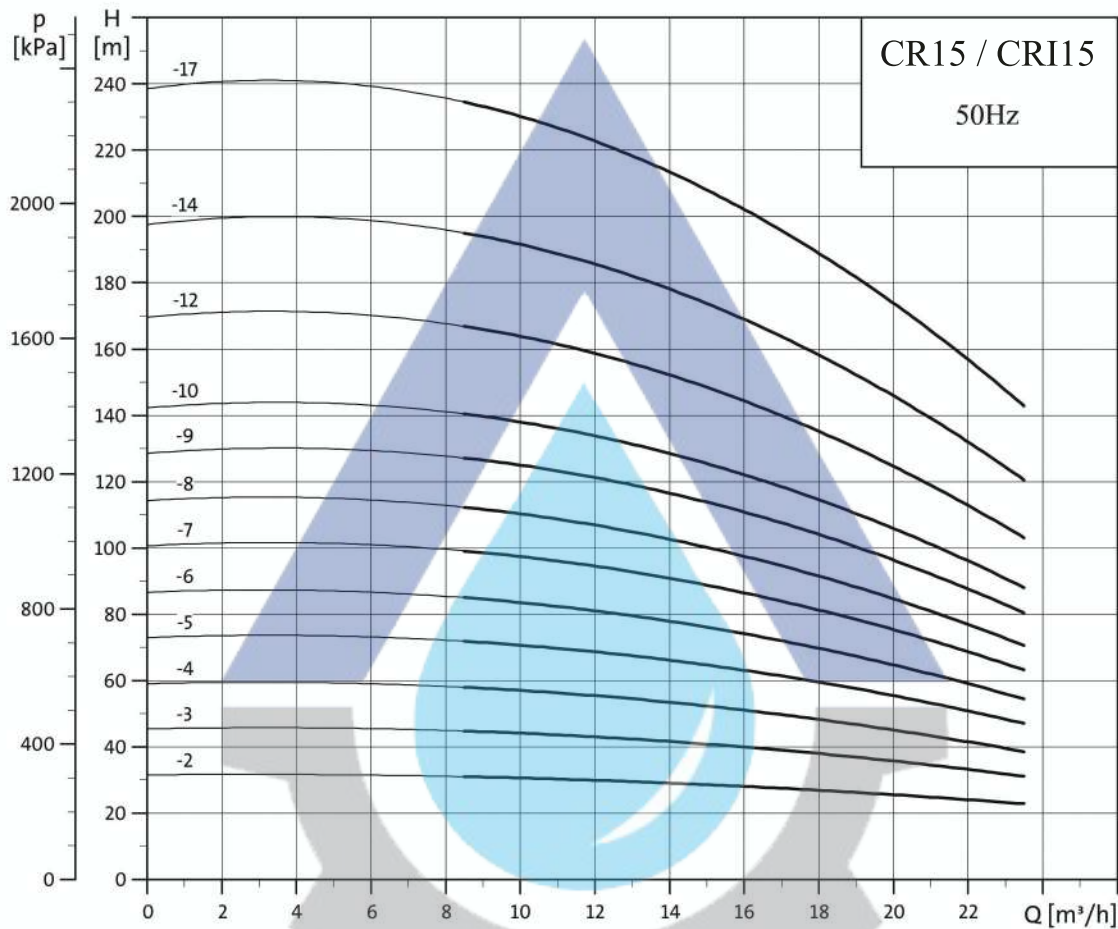

Dimensional sketches

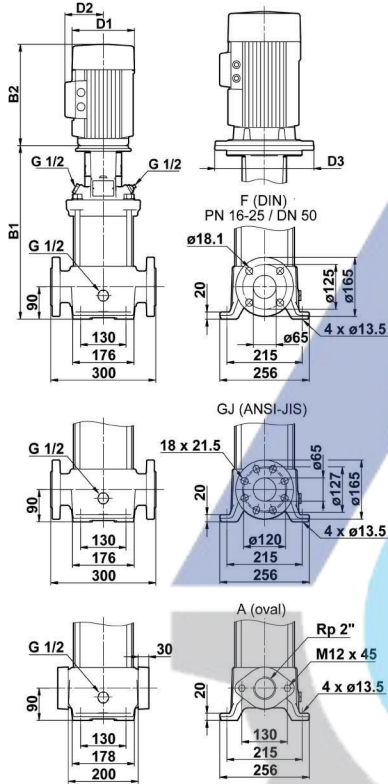

Dimensions and weights

Pump type	Dimensions [mm]						Net weight [kg]		
	Oval flange		DIN flange			Oval flange	DIN flange		
	B1	B1+B2	B1	B1+B2	D1	D2	D3	Oval	DIN
CR15-2	415	750	415	750	178	110	-	53.0	54.0
CR15-3	465	837	465	837	220	134	-	65.0	66.0
CR15-4	510	882	510	882	220	134	-	66.0	66.0
CR15-5	555	946	555	946	220	134	300	76.1	77.1
CR15-6	632	1023	632	1023	220	134	300	89.0	90.0
CR15-7	677	1068	677	1068	220	134	300	93.9	94.9
CR15-8	-	-	722	1113	220	134	300	-	95.0
CR15-9	-	-	767	1231	260	172	352	-	122.0
CR15-10	-	-	889	1353	260	172	352	-	129.0
CR15-12	-	-	979	1443	260	172	352	-	13.0
CR15-14	-	-	1069	1547	306	197	352	-	150.0
CR15-17	-	-	1204	1682	306	197	352	-	155.0

Electrical data

3 x 380-415 V, 50 Hz

Pump type	Motor P ₂ [kW]	Full load current I _{L1} [A]	Power factor Cos φ 1/1	Motor efficiency η [%]	I _{start} / I _{L1}
CR15-2	3.0	6.25	0.88-0.82	86.0-86.0	7.8-8.5
CR15-3	4.0	8.00	0.90-0.87	87.0-87.0	8.7-9.5
CR15-4	4.0	8.00	0.90-0.87	87.0-87.0	8.7-9.5
CR15-5	5.5	11.0	0.89-0.86	87.5-87.5	8.9-9.7
CR15-6	5.5	11.0	0.89-0.86	87.5-87.5	8.9-9.7
CR15-7	7.5	15.2	0.87-0.81	88.0-88.0	9.1-9.9
CR15-8	7.5	15.2	0.87-0.81	88.0-88.0	9.1-9.9
CR15-9	11.0	21.5	0.91-0.87	90.0-90.0	7.3-8.0
CR15-10	11.0	21.5	0.91-0.87	90.0-90.0	7.3-8.0
CR15-12	11.0	21.5	0.91-0.87	90.0-90.0	7.3-8.0
CR15-14	15.0	28.7	0.87	90.0	6.0
CR15-17	15.0	28.7	0.87	90.0	6.0

Midd, East

GRUNFARS



Pumps

CR16 & CRI16 SERIES

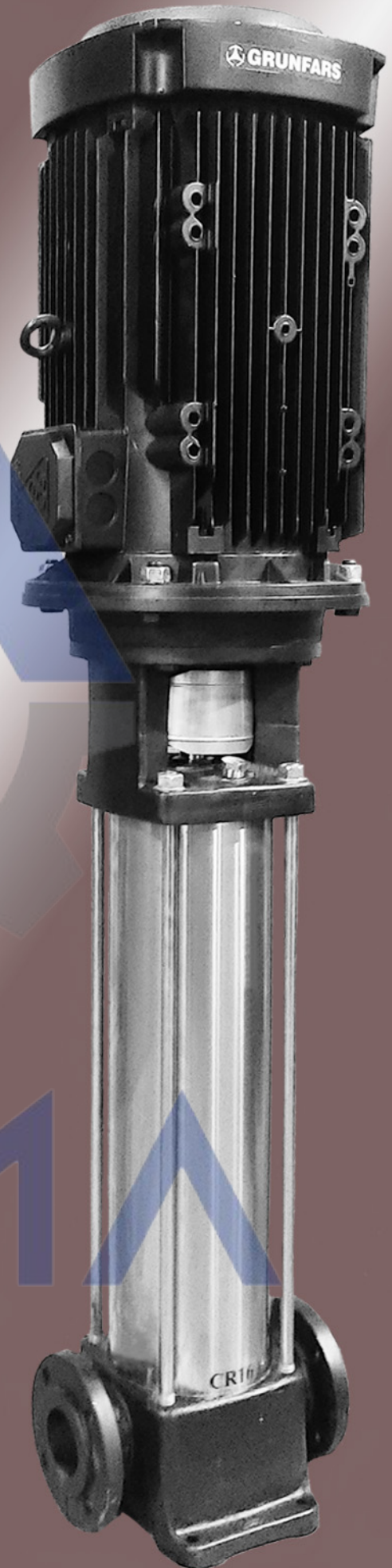
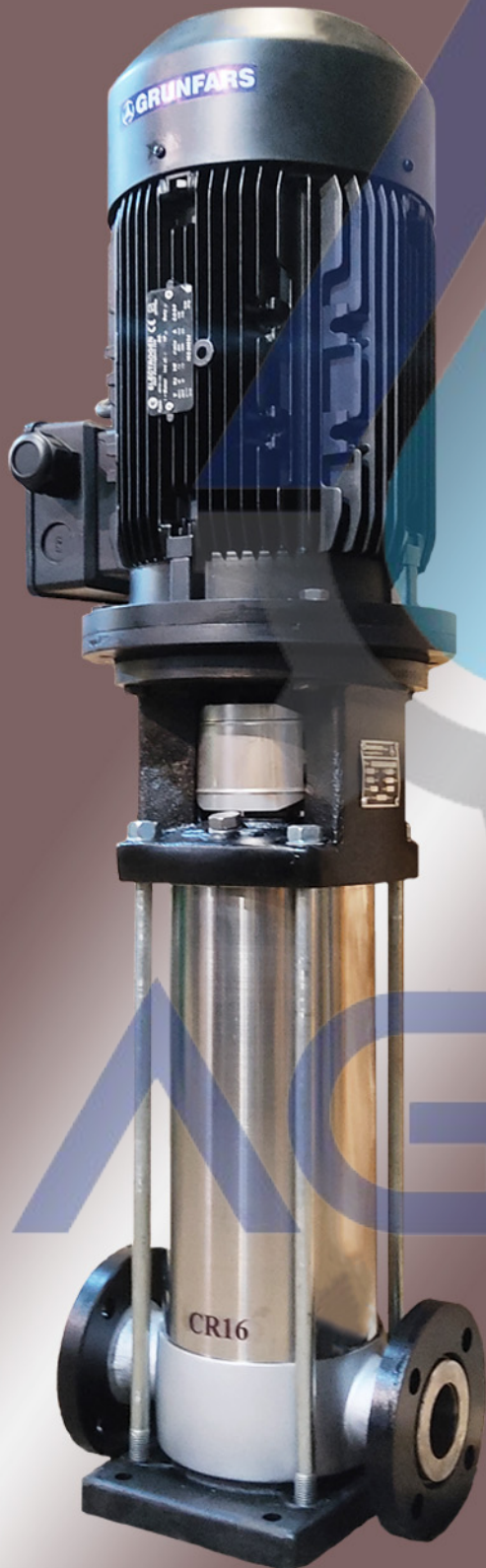

AGM



CR16 / CRI16

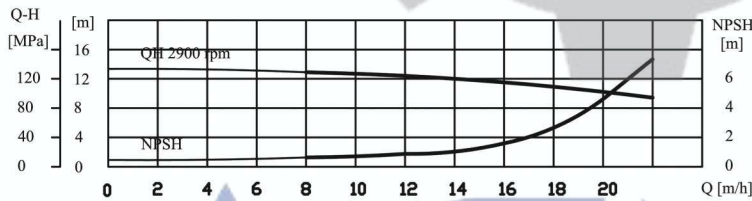
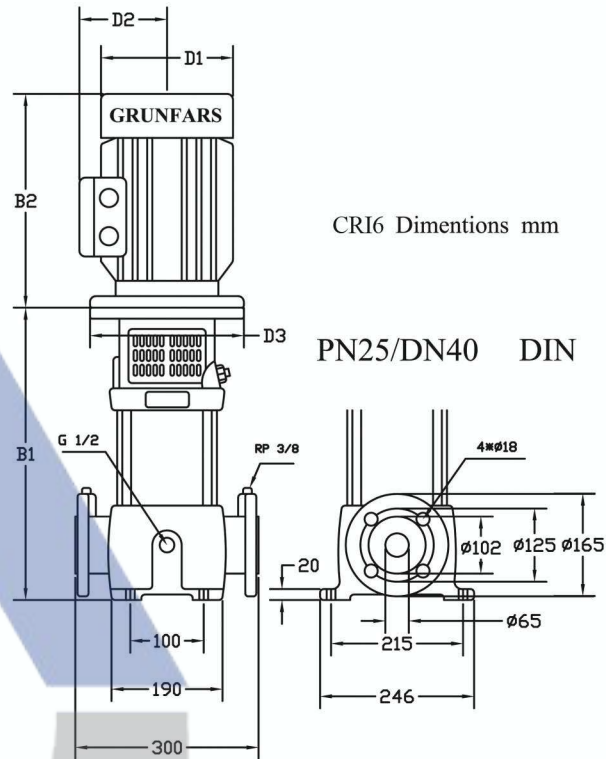
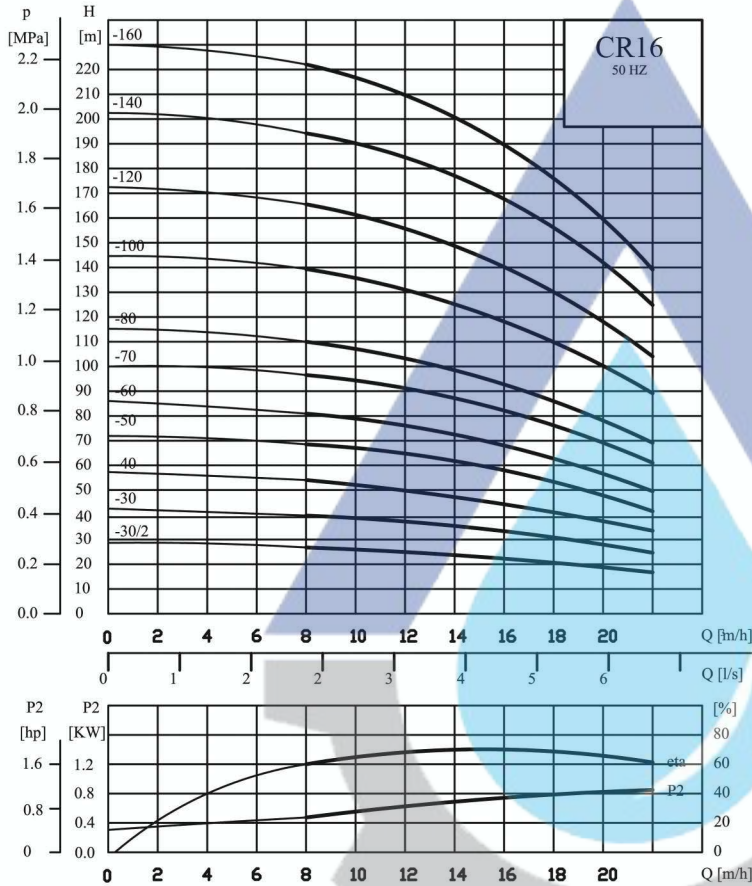

Dimensions and weights

pump type	DIMENSIONS [mm]						Net Weight [kg]
	B1	B2	B1+B2	D1	D2	D3	
CR16-30/2	460	280	740	180	110		50
CR16-30	460	335	795	180	110		55
CR16-40	505	370	875	180	135		60
CR16-50	570	390	960	220	135	300	80
CR16-60	615	390	1005	220	135	300	85
CR16-70	660	390	1050	220	135	300	90
CR16-80	705	390	1095	220	135	300	90
CR16-100	825	465	1290	260	170	350	125
CR16-120	915	465	1380	260	170	350	130
CR16-140	1005	505	1510	325	250	350	175
CR16-160	1095	505	1600	325	250	350	180

Pipework connection
DIN 2566 with threaded socket
DIN/2634 with socket for welding

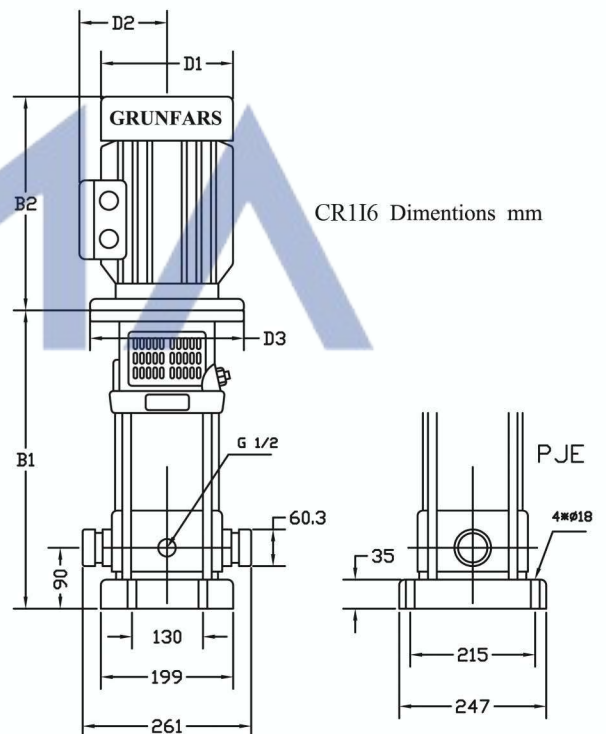

Materials CR16 / CRI16

POS. NO.	Description	Materials	DIN W.-NO	AISI / ASTM
1	Pump head	Cast iron GG20	0.6020	ASTM 25B
* 2	Cupling guard	stainless steel	1.4301	AISI 304
3	shaft	stainless steel	1.4401 1.4057	AISI 316 AISI 431
* 4	impeller	stainless steel	1.4301	AISI 304
* 5	intermediate chamber	stainless steel	1.4301	AISI 304
* 6	Outer sleeve	stainless steel	1.4301	AISI 304
	Stay bolts	stainless steel or steel 50	1.4057 1.0531	AISI 431
* 7	Base	Cast iron GG20	0.6020	ASTM 25B
8	Neck ring	Teflon		
9	shaft seal	Tungesten carbide Silicon carbide		
	Rubber parts in pump	EPDM or FPM (viton)		

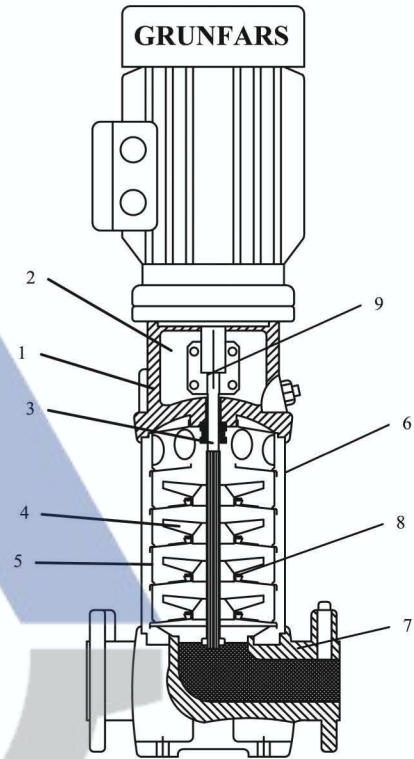

Material for Position No. Marked * in GPRN Type is -
Stainless Steel (1.4401 AISI 316)

Electrical Data

3 X 380-415 V , 50 HZ

pump type	Motor		Full load current I _{1/1} [A]	Power Factor Cosφ 1/1	Motor Efficiency η [%]	$\frac{I_{start}}{I_{1/1}}$
	[KW]	[hp]				
CR16-30/2	2.2	3.0	4.75	0.87-0.82	84	7.0-7.6
CR16-30	3.0	4.0	6.25	0.88-0.82	86	7.8-8.5
CR16-40	4.0	5.5	8.00	0.90-0.87	87	8.7-9.5
CR16-50	5.5	7.5	11.0	0.89-0.86	88.5	8.9-9.7
CR16-60	5.5	7.5	11.0	0.89-0.86	88.5	8.9-9.7
CR16-70	7.5	10	15.2	0.87-0.81	89	9.1-9.9
CR16-80	7.5	10	15.2	0.87-0.81	89	9.1-9.9
CR16-100	11	15	21.5	0.91-0.87	85	7.3-8.0
CR16-120	11	15	21.5	0.91-0.87	85	7.3-8.0
CR16-140	15	20	29.4-27.1	0.88	88.2-87.9	7.0-7.8
CR16-160	15	20	29.4-27.1	0.88	88.2-87.9	7.0-7.8

Motors : Enclosure clas IP55

Standard 50HZ voltages available:

3x220-240/380-415 V-motors up to 3kw

3x380-415V-motors from 4kw and upwards

1x240V-motors up to 2.2kw

Motors for other voltages available on request

All motors must be connected to a motor starter
in accordance with local regulations

Mid East GRUNFARS



Pumps

CR 20 Series

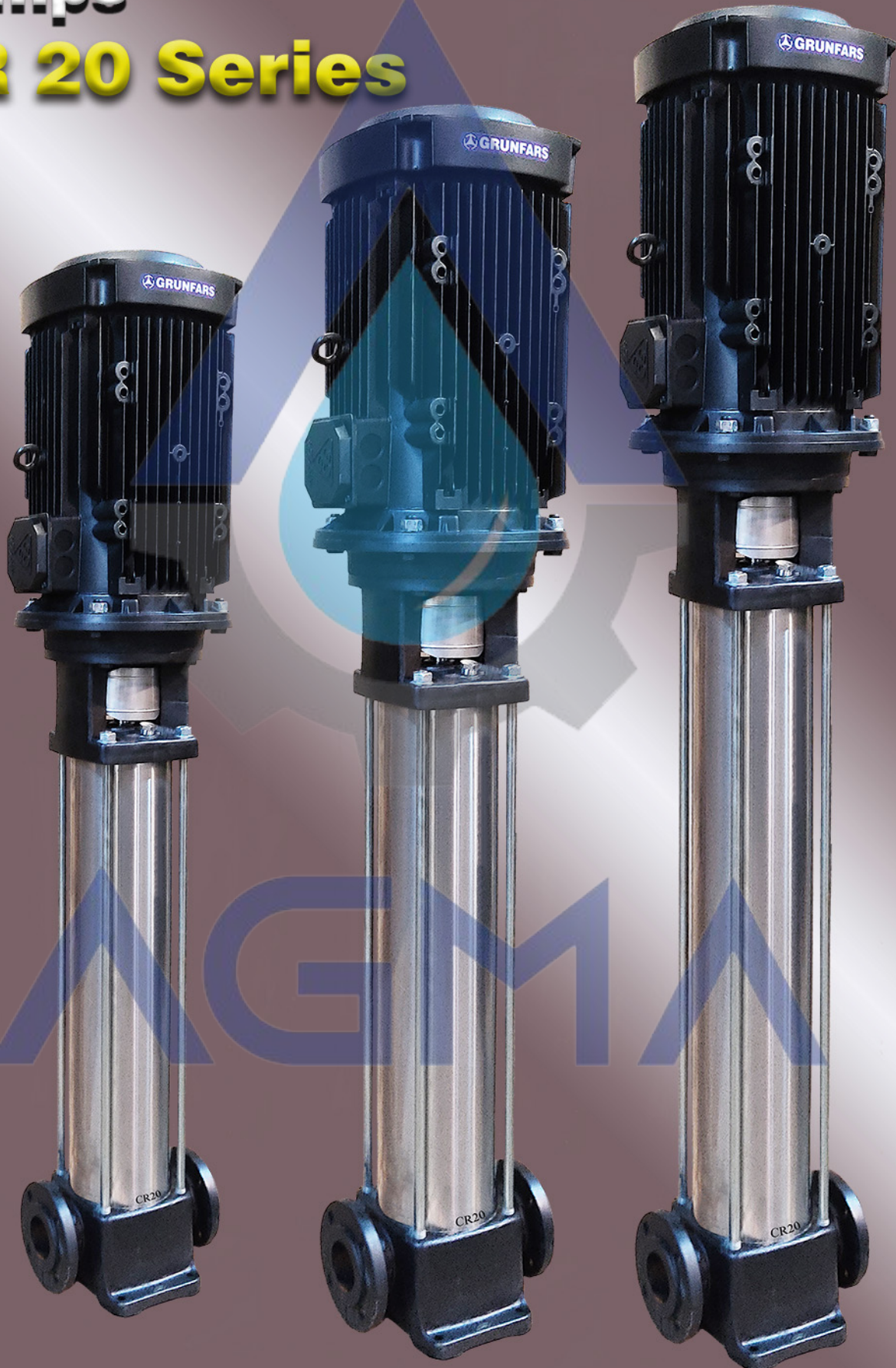



Performance curves

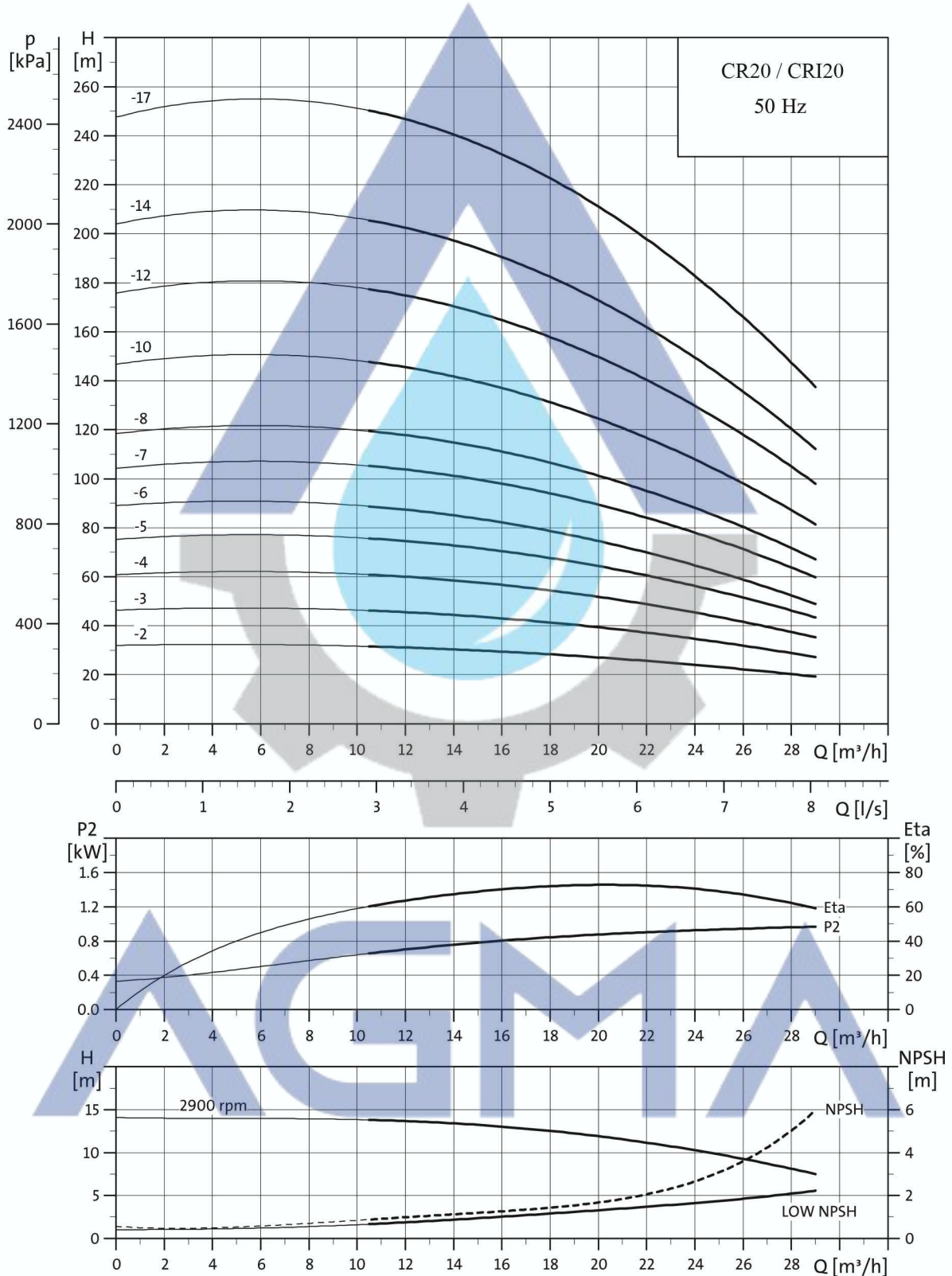

Dimensional sketches

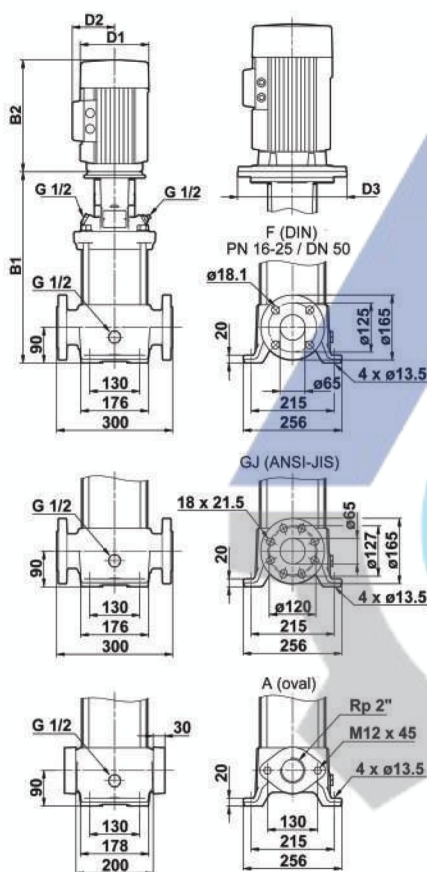

Dimensions and weights

Pump type	Dimensions [mm]							Net weight [kg]		
	Oval flange		DIN flange			D1	D2	D3	Oval flange	DIN flange
	B1	B1+B2	B1	B1+B2	Oval				DIN	
CR20-2	415	750	415	750	178	110	-	53.0	54.0	
CR20-3	465	837	465	837	220	134	-	64.0	65.0	
CR20-4	542	933	542	933	220	134	300	87.0	87.0	
CR20-5	587	978	587	978	220	134	300	90.9	91.9	
CR20-6	632	1023	632	1023	220	134	300	92.0	93.0	
CR20-7	677	1141	677	1141	260	172	352	118.0	119.0	
CR20-8	-	-	799	1263	260	172	352	-	126.0	
CR20-10	-	-	889	1353	260	172	352	-	129.0	
CR20-12	-	-	979	1457	306	197	352	-	147.0	
CR20-14	-	-	1069	1547	306	197	352	-	150.0	
CR20-17	-	-	1204	1682	306	197	352	-	165.0	

Electrical data

3 x 380-415 V, 50 Hz

Pump type	Motor P ₂ [kW]	Full load current I _{1/1} [A]	Power factor Cos φ 1/1	Motor efficiency η [%]	I _{start} / I _{1/1}
CR20-2	3.0	6.25	0.88-0.82	86.0-86.0	7.8-8.5
CR20-3	4.0	8.00	0.90-0.87	87.0-87.0	8.7-9.5
CR20-4	5.5	11.0	0.89-0.86	87.5-87.5	8.9-9.7
CR20-5	7.5	15.2	0.87-0.81	88.0-88.0	9.1-9.9
CR20-6	7.5	15.2	0.87-0.81	88.0-88.0	9.1-9.9
CR20-7	11.0	21.5	0.91-0.87	90.0-90.0	7.3-8.0
CR20-8	11.0	21.5	0.91-0.87	90.0-90.0	7.3-8.0
CR20-10	11.0	21.5	0.91-0.87	90.0-90.0	7.3-8.0
CR20-12	15.0	28.7	0.87	90.0	6.0
CR20-14	15.0	28.7	0.87	90.0	6.0
CR20-17	18.5	35.9-34.1	0.86	91.0	7.2

Midd, East

GRUNFARS

Pumps



CR32 & CRI32 SERIES

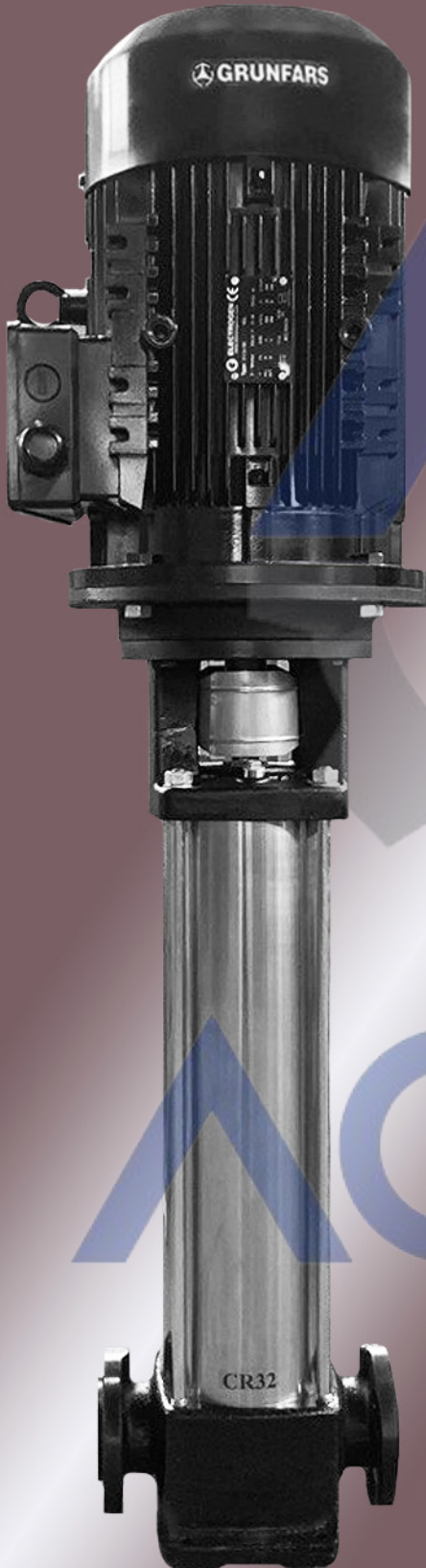

AGM



Performance curves

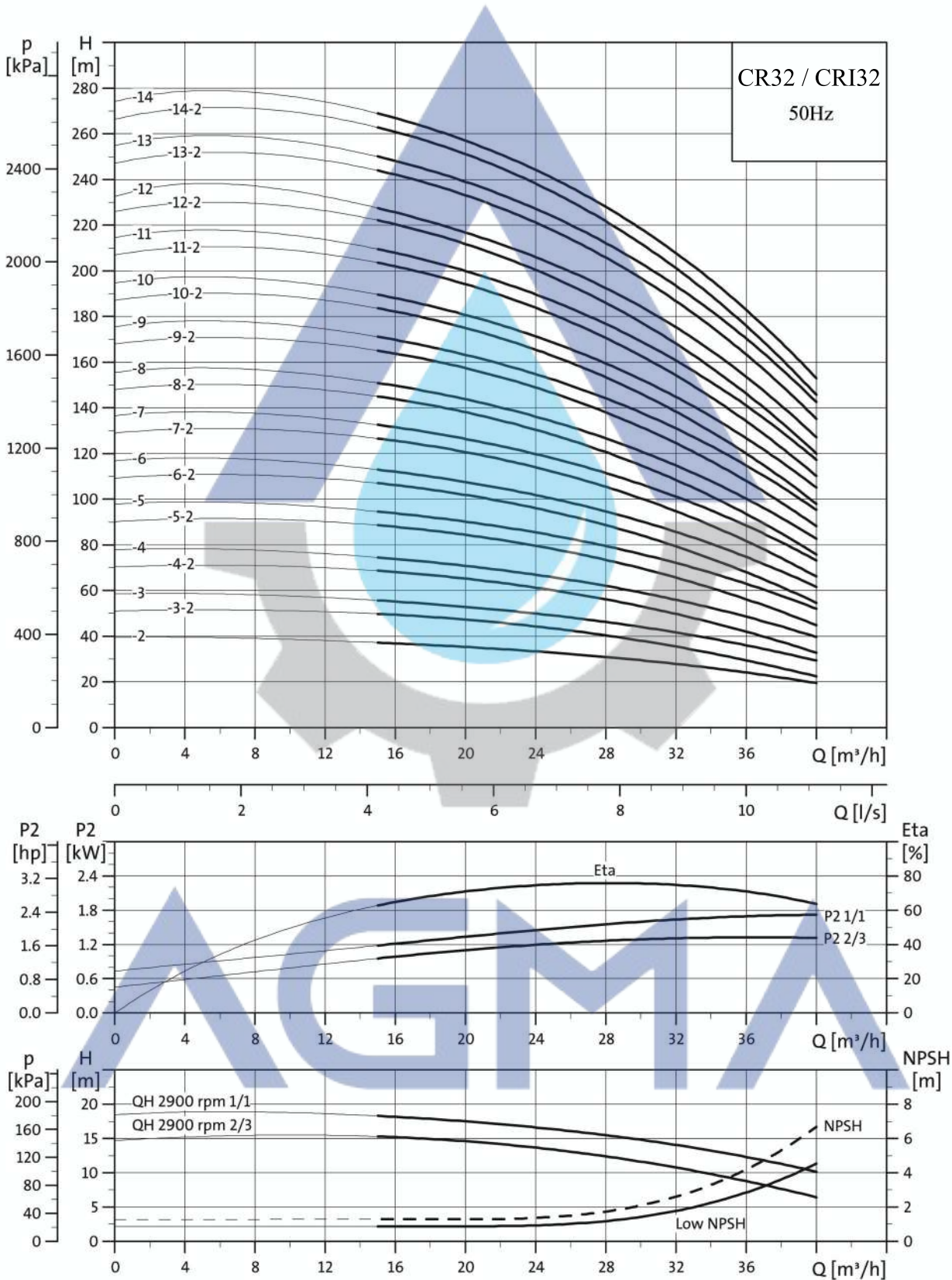

Dimensional sketches

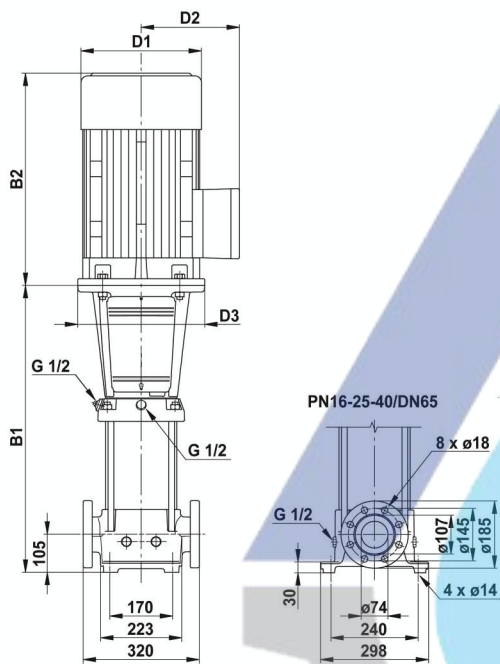

Dimensions and weights

Pump type	Dimensions [mm]						Net weight [kg]
	B1	B2	B1 + B2	D1	D2	D3	
CR32-2	575	372	947	220	134	158	98
CR32-3-2	645	391	1036	220	134	298	107
CR32-3	645	391	1036	220	134	298	107
CR32-4-2	715	391	1106	220	134	298	115
CR32-4	715	391	1106	220	134	298	115
CR32-5-2	895	464	1359	260	172	350	156
CR32-5	895	464	1359	260	172	350	156
CR32-6-2	965	464	1429	260	172	350	160
CR32-6	965	464	1429	260	172	350	160
CR32-7-2	1035	478	1513	306	197	350	197
CR32-7	1035	478	1513	306	197	350	197
CR32-8-2	1105	478	1583	306	197	350	201
CR32-8	1105	478	1583	306	197	350	201
CR32-9-2	1175	478	1653	306	197	350	215
CR32-9	1175	478	1653	306	197	350	215
CR32-10-2	1245	478	1723	306	197	350	219
CR32-10	1245	478	1723	306	197	350	219
CR32-11-2	1315	600	1915	364	269	350	276
CR32-11	1315	600	1915	364	269	350	276
CR32-12-2	1385	600	1985	364	269	350	280
CR32-12	1385	600	1985	364	269	350	280
CR32-13-2	1455	667	2122	404	306	400	362
CR32-13	1455	667	2122	404	306	400	362
CR32-14-2	1525	667	2192	404	306	400	366
CR32-14	1525	667	2192	404	306	400	366

Electrical data

3 x 380-415 V, 50 Hz

Pump type	Motor P ₂ [kW]	Full load current I _{1/1} [A]	Power factor Cos φ 1/1	Motor efficiency η [%]	I _{start} I _{1/1}
CR32-2	4.0	8.00	0.90-0.87	87.0	8.7-9.5
CR32-3-2	5.5	11.0	0.89-0.86	88.5	8.9-9.7
CR32-3	5.5	11.0	0.89-0.86	88.5	8.9-9.7
CR32-4-2	7.5	15.2	0.87-0.81	89.0	9.1-9.9
CR32-4	7.5	15.2	0.87-0.81	89.0	9.1-9.9
CR32-5-2	11.0	21.5	0.91-0.87	85.0	7.3-8.0
CR32-5	11.0	21.5	0.91-0.87	85.0	7.3-8.0
CR32-6-2	11.0	21.5	0.91-0.87	85.0	7.3-8.0
CR32-6	11.0	21.5	0.91-0.87	85.0	7.3-8.0
CR32-7-2	15.0	28.7	0.87	86.0	6.0
CR32-7	15.0	28.7	0.87	86.0	6.0
CR32-8-2	15.0	28.7	0.87	86.0	6.0
CR32-8	15.0	28.7	0.87	86.0	6.0
CR32-9-2	18.5	35.9-34.1	0.86	87.0	7.2
CR32-9	18.5	35.9-34.1	0.86	87.0	7.2
CR32-10-2	18.5	35.9-34.1	0.86	87.0	7.2
CR32-10	18.5	35.9-34.1	0.86	87.0	7.2
CR32-11-2	22.0	42.0-40.0	0.86	89.2	7.3
CR32-11	22.0	42.0-40.0	0.86	89.2	7.3
CR32-12-2	22.0	42.0-40.0	0.86	89.2	7.3
CR32-12	22.0	42.0-40.0	0.86	89.2	7.3
CR32-13-2	30.0	56.0-52.0	0.88	91.7	7.5
CR32-13	30.0	56.0-52.0	0.88	91.7	7.5
CR32-14-2	30.0	56.0-52.0	0.88	91.7	7.5
CR32-14	30.0	56.0-52.0	0.88	91.7	7.5